

JBC

The Soldering Co.



Cartridge Guide

Feel the quality, be exclusive

Index

| | |
|---|----|
| Most Efficient Soldering System..... | 4 |
| Bigger is better | 6 |
| Factors limiting tip life | 7 |
| Cleaning Systems | 8 |
| C115 Cartridge Range for NT115, AN115 and NP115 Nano Tools | 12 |
| C120 Cartridge Range for PA120 and AM120 Micro Tweezers | 16 |
| C210 Cartridge Range for T210 Precision Handles | 18 |
| C245 Cartridge Range for T245 General Purpose Handles..... | 22 |
| C245E Extended Tip Life Cartridge Range for T245 General Purpose Handles | 44 |
| C250 Cartridge Range for AL250 Auto-Feed Iron and AP250 Solder Feed Iron | 46 |
| C420 Cartridge Range for AT420 and HT420 Thermal Tweezers..... | 49 |
| C470 Cartridge Range for T470 HD Handles and HT470 HD Thermal Tweezers..... | 51 |
| C360 Tip Range for DS360 Micro Desoldering Iron | 59 |
| C560 Tip Range for DR560 Desoldering Iron..... | 61 |
| W140 Blade Cartridge Range for WS140 Precision High-Temperature Wire Stripper Tweezers | 63 |
| W440 Blade Cartridge Range for WS440 High-Temperature Wire Stripper Tweezers | 65 |

A global organization at your service

JBC is a global company with a distributor network spanning 5 continents that guarantees a solid commercial organization with quick and efficient service.

The power of experience

More than 90 years of experience have placed JBC at the technological forefront of tools for soldering and rework operations in electronics. Innovation, efficiency and reliability are the key features of a wide range of products which have been designed to satisfy the most demanding requirements of professionals.

High technology, superior quality

Product perfection is one of the main objectives of JBC's improvement and development program. The R&D department has created the most innovative soldering technologies, which JBC is proud to present in this catalogue.

CE
ESD safe

All JBC products comply with CE standards and ESD recommendations.



Most Efficient Soldering System

JBC Exclusive Heating System

JBC Stations work with JBC Exclusive Heating System, which recovers tip temperature extremely quickly. This increases work efficiency and allows the user to work with lower temperatures.

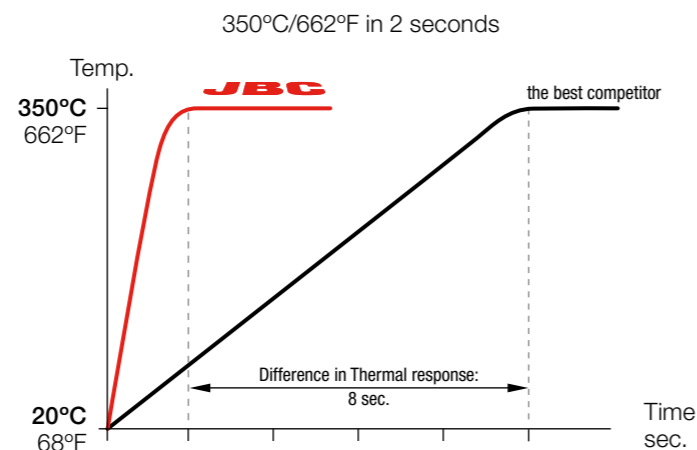

*This graph compares JBC C210 Cartridge Range to the equivalent cartridges of the best competitor.

Enhanced Temperature Efficiency ➔ Increased Productivity + Better Quality

Efficient Temperature Control

Comparative process of 3 solder joints

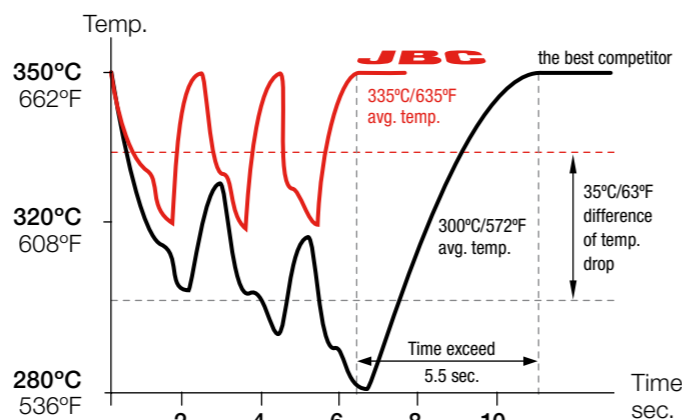

Tips with JBC technology only drop 30°C (54°F) where others drop as much as 70°C (126°F)

Intelligent Heat Management

Thanks to automatic detection of the tool in the stand, JBC Soldering and Rework Stations allow the tools to enter into **Sleep & Hibernation** Modes when not being used. As a result, tip life lasts up to 5 times longer.

Sleep Mode

Sleep Mode automatically lowers tip temperature below the solder melting point when the tool rests in the stand. It prevents the dissolution of the tip iron coating into molten solder.

Hibernation Mode

After a configurable period of tool inactivity in the stand, the tool enters into **Hibernation Mode**. It cuts off the power supply making the tip reach room temperature thus preventing oxidation and saving energy.

Longer Tip life

Tip life increases exponentially by using lower temperatures as shown. Using Sleep Mode, the temperature is further reduced, which multiplies tip life by 5.

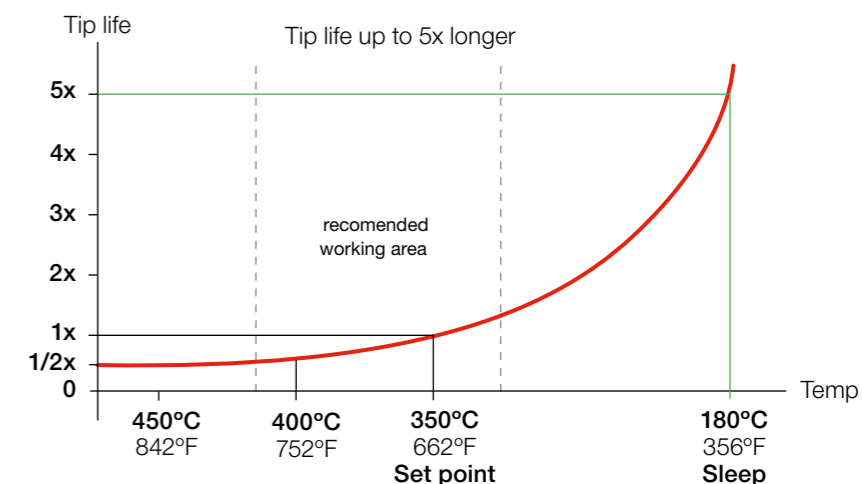
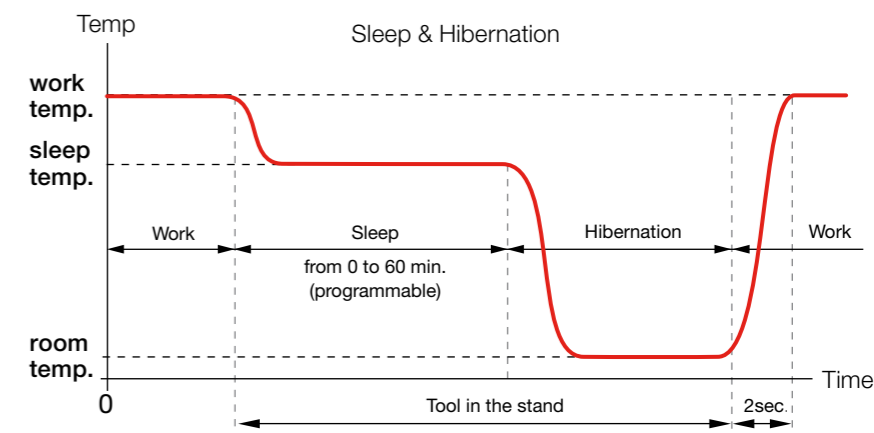

Cartridges with extended tip life

The essential part of the soldering iron is the tip. Therefore, JBC has over 500 cartridge models of different shapes and sizes to choose from, depending on each application. JBC has developed the most advanced technology based on the following principles:

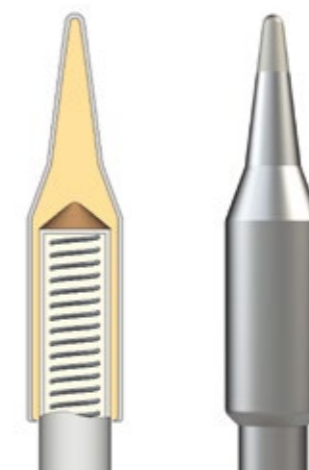

- **Excellent Heat Transfer**
The compact element reduces thermal barriers.
- **Instantaneous Heating**
A fully-integrated thermal sensor in the heater ensures quick temperature recovery.
- **Great Durability**
The intelligent algorithm control program extends tip life.

When you start working do not forget:

Bigger is better

The bigger the solder tip, the better the thermal transfer. Select the tip that has the greatest contact area.

Over 500 tips of different sizes, shapes and power

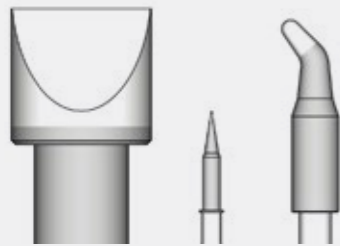

JBC Cartridges range from models for precision work to high power requirement applications.

Geometry Slimness vs Efficiency

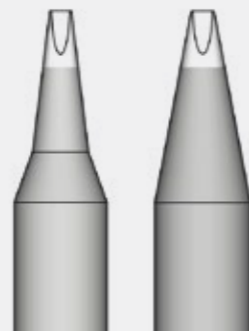

A tip with high thermal efficiency makes your job up to **40% faster** than a tip with a slimmer geometry.

Increase the contact surface Tip - Application

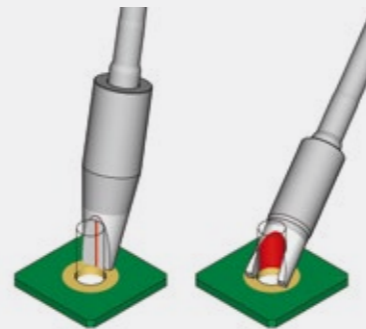

The bigger the contact surface that the tip has with the application, the higher the **thermal transfer**.

Largest mass possible

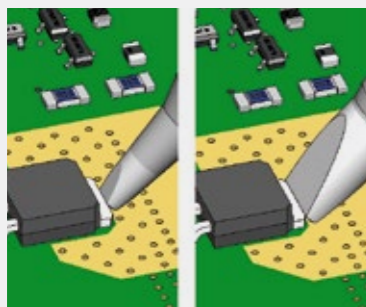

The more mass the tip has, the more heat is accumulated and the **lower is the temperature drop**.

Maintain tip surface clean and tinned



Remember that rusty and dirty surfaces reduce **heat transfer** to the solder joint.

(See JBC's cleaning methods on pages 8-9).

This way you will be able to:

- ▶ work at **lower temperatures** (350°C / 662°F).
- ▶ obtain **better results** in **less time**.
- ▶ improve **thermal performance**.
- ▶ increase **temperature precision**.
- ▶ reduce **collateral damage** (thermal shock on components and PCBs).

Factors limiting tip life

Working temperature

The higher the temperature, the greater the oxidation and corrosion. Work with the **lowest possible temperature** and choose the tip with the greatest contact area for each application. **Use thermally efficient tools** and keep tips clean of oxidation.

Correct techniques

Too much pressure on the surface to solder can cause tip or plate breakage. Do not use the tip as a pointed object or a screwdriver. Choose the **right temperature and tip shape for each application**.

Iron plate thickness

Iron plate wear shortens tip life by hollowing tips out. Do not use mechanical or chemical means to clean the tip. Use the **cleaning methods provided by the manufacturer** - such as brass wool, automatic tip cleaner or sponges.

Oxidization

An oxidized soldering iron does neither wet nor transfer heat well (dewetting). The higher the temperature, the greater the risk of oxidation. **Always keep tips tinned while not in use** and take advantage of **JBC Sleep & Hibernation Modes**.

Flux and solder alloy

Too much active flux can cause corrosion. **IPC recommends: ROL, REL and ORL**. Flux quantity inside small diameter solder wires might not be enough. **Provide compatible external flux if necessary**.

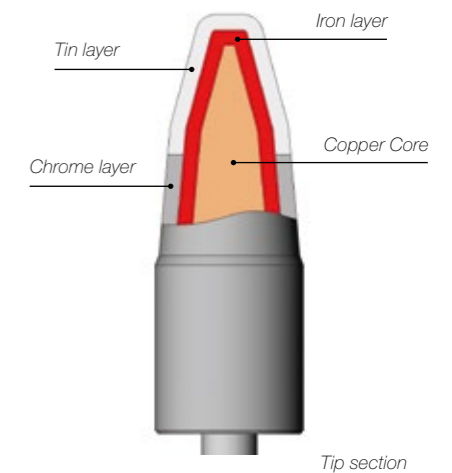

Remember

- ▶ Work with the **lowest possible temperature**.
- ▶ Use **thermally efficient tools**.
- ▶ Choose the **right temperature and tip shape for each application**.
- ▶ **IPC recommends: ROL, REL and ORL**.
- ▶ **Always keep tips tinned while not in use**.
- ▶ Take advantage of **JBC Sleep & Hibernation Modes**.
- ▶ **Too much pressure** on the surface to solder can cause **tip or plate breakage**.
- ▶ Use the **cleaning methods provided by the manufacturer**.



Cleaning Systems

For good thermal transfer, keep the tip tinned thus free from oxides.

Clean the tip in less than a second



With automatic cleaners you **save time** and **optimize production**.

Improve heat transfer

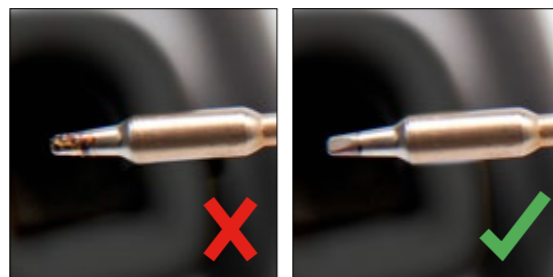

A clean tip is always easier to tin, resulting in **higher quality solder joints**.

JBC offers effective, practical and affordable methods to prevent splashing and extend tip life:

Easy to empty



The solder collector tray can be **easily emptied** and **re-used** with no wear and tear.

Keep your work area clean



The locking mechanism on the brushes makes them **fast and easy to replace**.

CLM Manual Tip Cleaner

► A complete cleaning system with splashguard and antisplash membrane to keep the work area clean and free of solder particles.

Antisplash rubber

Ref. **CL7882**
Prevent splashing of solder particles and maintain the work area clean.

Brass Wool

Ref. **CL6210**
Very effective cleaning method. It leaves a small layer of solder on the tip to prevent oxidation between cleaning and rewetting.



ESD-safe Tip Wiper

Ref. **CL8010**
A temperature-resistant receptacle lets the operator remove excess solder by gently tapping or wiping.

Sponge

Ref. **S0354**
The least harmful cleaning method. Keep the sponge moist with distilled water when working to avoid tip wear.



Non-slip Base

No need to hold the base while cleaning tips.

CLU Senior Tip Cleaner

► Continuous or Sensor Mode

This cleaner is excellent for cleaning tips of different shapes and sizes. You can easily switch between sensor and continuous mode by pressing the top buttons.



It also features a second position which facilitates vertical tip access

Brushes for CLU



Ref. **CLU8**
Metal Brushes

Ref. **CLU7**
Metal Brushes

Ref. **CLUP1**
Non-Metal Brushes

Ref. **CLUP7**
Non-Metal Brushes

Ref. **CLUP2**
High Melting Point
Non-Metal Brushes

Ref. **CLUP8**
High Melting Point
Non-Metal Brushes



Our Cartridge Range is steadily growing as we are determined to respond to our clients' specific needs, cooperating closely with them to create **the right solution.**

C115 Cartridge Range for NT115, AN115 and NP115 Nano Tools





| Ref. | Description | Image and dimensions | Suggested components | Compatible with |
|----------------|---|----------------------|--|---|
| C115116 | Chisel Cartridge 0.2 x 0.1 mm 0.008 x 0.004 in | | Package 01005, 0201 Very fine pitch 0.4 mm QFP, IC | Stations: NAS, NAN Tools: NT115, AN115, NP115 |
| C115117 | Chisel Cartridge 0.4 x 0.2 mm 0.016 x 0.008 in | | Package 0402 Very fine pitch 0.65 mm QFP, IC | Stations: NAS, NAN Tools: NT115, AN115, NP115 |
| C115108 | Chisel Cartridge 0.6 x 0.3 mm 0.024 x 0.012 in | | Package 0603 PLCC, SO, SOT | Stations: NAS, NAN Tools: NT115, AN115, NP115 |
| C115125 | Chisel Cartridge 1 x 0.2 mm 0.039 x 0.008 in | | Package 0805 Difficult to reach | Stations: NAS, NAN Tools: NT115, AN115, NP115 |
| C115113 | Chisel Cartridge 1 x 0.3 mm 0.039 x 0.012 in | | Package 0805 Through-hole | Stations: NAS, NAN Tools: NT115, AN115, NP115 |
| C115213 | Chisel Cartridge 1 x 0.3 S1 mm 0.039 x 0.012 in | | Package 0805 Through-hole High thermal performance | Stations: NAS, NAN Tools: NT115, AN115, NP115 |
| C115221 | Chisel Cartridge 1.3 x 0.3 mm 0.051 x 0.012 in | | Package 0805 Through-hole High thermal performance | Stations: NAS, NAN Tools: NT115, AN115, NP115 |





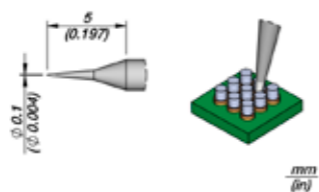
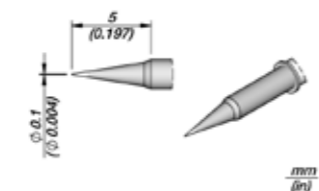
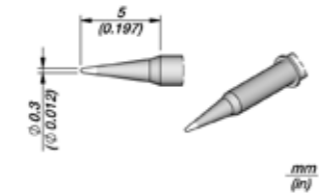
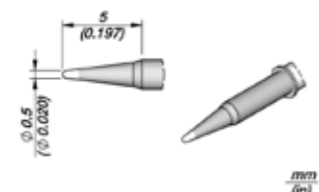
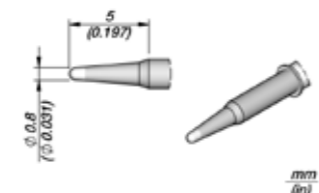

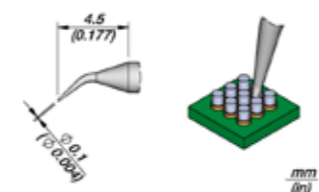
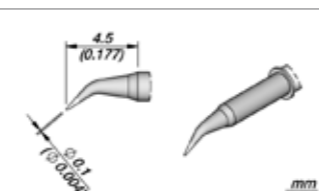
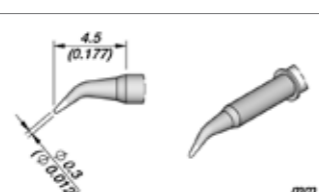

C115 Cartridge Range for NT115, AN115 and NP115 Nano Tools

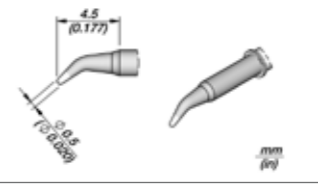
| Ref. | Description | Image and dimensions | Suggested components | Compatible with |
|----------------|---|----------------------|--|---|
| C115222 | Chisel Cartridge 1.6 x 0.3 mm 0.063 x 0.012 in | | Package 0805 Through-hole High thermal performance | Stations: NAS, NAN Tools: NT115, AN115, NP115 |
| C115114 | Chisel Cartridge 1.8 x 0.5 mm 0.071 x 0.020 in | | Package 0805 Through-hole High thermal performance | Stations: NAS, NAN Tools: NT115, AN115, NP115 |
| C115214 | Chisel Cartridge 1.8 x 0.5 mm S1 0.071 x 0.020 in | | Package 1206, 1210 Through-hole | Stations: NAS, NAN Tools: NT115, AN115, NP115 |
| C115131 | Chisel Cartridge 2 x 0.35 mm 0.079 x 0.014 in | | LED SMD 2727, 1921, 1415 | Stations: NAS, NAN Tools: NT115, AN115, NP115 |
| C115223 | Chisel Cartridge 2.4 x 0.6 mm 0.094 x 0.024 in | | Package 0805 Through-hole High thermal performance | Stations: NAS, NAN Tools: NT115, AN115, NP115 |
| C115109 | Bevel Cartridge Ø 0.6 mm Ø 0.024 in | | Package 0805 Through-hole | Stations: NAS, NAN Tools: NT115, AN115, NP115 |
| C115127 | Bevel Cartridge Ø 1 mm Ø 0.039 in | | Package 0805 Through-hole | Stations: NAS, NAN Tools: NT115, AN115, NP115 |
| C115128 | Spoon Cartridge Ø 1 mm Ø 0.039 in | | Package 0805 Through-hole | Stations: NAS, NAN Tools: NT115, AN115, NP115 |

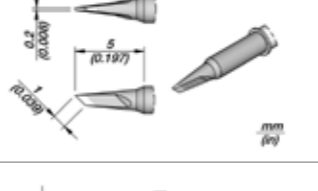
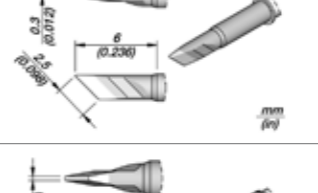
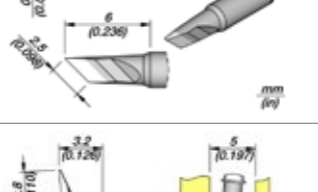
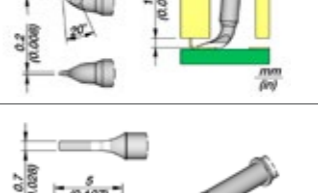
C115 Cartridge Range for NT115, AN115 and NP115 Nano Tools

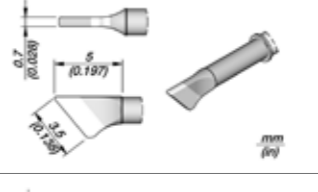
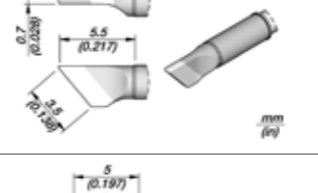
| | Ref. | Description | Image and dimensions | Suggested components | Compatible with |
|---|----------------|---|---|--|---|
|  | C115126 | Conical Cartridge Ø 0.1 mm S1 Ø 0.004 in |  | Package 01005 Very fine pitch 0.4 mm QFP, IC | Stations: NAS, NAN Tools: NT115, AN115, NP115 |
| | C115101 | Conical Cartridge Ø 0.1 mm Ø 0.004 in |  | Package 01005 Very fine pitch 0.4 mm QFP, IC | Stations: NAS, NAN Tools: NT115, AN115, NP115 |
| | C115103 | Conical Cartridge Ø 0.3 mm S1 Ø 0.012 in |  | Package 0201, 0402 Very fine pitch 0.65 mm QFP, IC | Stations: NAS, NAN Tools: NT115, AN115, NP115 |
| | C115106 | Conical Cartridge Ø 0.5 mm Ø 0.020 in |  | Package 0603 QFP, IC | Stations: NAS, NAN Tools: NT115, AN115, NP115 |
| | C115107 | Conical Cartridge Ø 0.8 mm Ø 0.031 in |  | General use | Stations: NAS, NAN Tools: NT115, AN115, NP115 |
|  | C115124 | Conical Bent Cartridge Ø 0.1 mm S1 Ø 0.004 in |  | Package 01005 Very fine pitch 0.4 mm QFP, IC | Stations: NAS, NAN Tools: NT115, AN115, NP115 |
| | C115118 | Conical Bent Cartridge Ø 0.1 mm Ø 0.004 in |  | Package 01005 Very fine pitch 0.4 mm QFP, IC | Stations: NAS, NAN Tools: NT115, AN115, NP115 |
| | C115105 | Conical Bent Cartridge Ø 0.3 mm Ø 0.012 in |  | Package 0201, 0402 Fine pitch 0.65 mm QFP, IC | Stations: NAS, NAN Tools: NT115, AN115, NP115 |

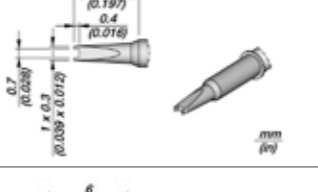
C115 Cartridge Range for NT115, AN115 and NP115 Nano Tools

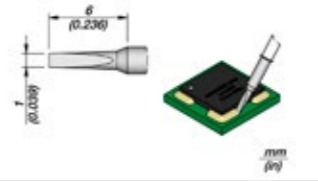
| | Ref. | Description | Image and dimensions | Suggested components | Compatible with |
|---|----------------|---|---|--|---|
|  | C115110 | Conical Bent Cartridge Ø 0.5 mm Ø 0.020 in |  | Package 0603 QFP, IC | Stations: NAS, NAN Tools: NT115, AN115, NP115 |
|  | C115120 | Knife Cartridge 1 x 0.2 mm 0.039 x 0.008 in |  | Drag soldering SMD Package 0805 Through-hole | Stations: NAS, NAN Tools: NT115, AN115, NP115 |
| | C115112 | Knife Cartridge 2.5 x 0.3 mm 0.098 x 0.012 in |  | Drag soldering SMD SO, SOT Package 1210, 1812, 2010, 2512 High thermal performance | Stations: NAS, NAN Tools: NT115, AN115, NP115 |
| | C115212 | Knife Cartridge 2.5 x 0.3 mm S1 0.098 x 0.012 in |  | Drag soldering SMD SO, SOT Package 1210, 1812, 2010, 2512 | Stations: NAS, NAN Tools: NT115, AN115, NP115 |
| | C115129 | Knife Cartridge 2.8 x 0.2 mm 0.110 x 0.008 in |  | IC, Difficult to reach | Stations: NAS, NAN Tools: NT115, AN115, NP115 |
|  | C115111 | Blade Cartridge 3.5 x 0.7 mm 0.138 x 0.028 in |  | Package 1210, 1812 SO, SOT | Stations: NAS, NAN Tools: NT115, AN115, NP115 |
| | C115211 | Blade Cartridge 3.5 x 0.7 mm S1 0.138 x 0.028 in |  | Package 1210, 1812 SO, SOT High thermal performance | Stations: NAS, NAN Tools: NT115, AN115, NP115 |
|  | C115132 | Chip Components Cartridge 0.7 mm 0.028 in |  | Package 0201 | Stations: NAS, NAN Tools: NT115, AN115, NP115 |
|  | C115115 | Conformal Coating Removal Steel Cartridge 1 mm 0.039 in |  | Stainless Steel Remove underfill encapsulants | Stations: NAS, NAN Tools: NT115, AN115, NP115 |



C120 Cartridge Range for PA120 and AM120 Micro Tweezers

| | Ref. | Description | Image and dimensions | Suggested components | Compatible with |
|--|----------------|---|----------------------|---|---|
| | C120001 | Conical Bent Cartridge Ø 0.2 mm Ø 0.008 in | | Package 0201, 0402 | Stations: CDP, DIU, DDU, DMU Tools: AM120, PA120 |
| | C120002 | Conical Bent Cartridge Ø 0.2 mm Ø 0.008 in | | Package 0201, 0402 | Stations: CDP, DIU, DDU, DMU Tools: AM120, PA120 |
| | C120902 | Conical Bent Cartridge Ø 0.3 mm Ø 0.012 in | | Package 0201, 0402 Fine pitch 0.65 mm QFP, IC | Stations: CDP, DIU, DDU, DMU Tools: AM120, PA120 |
| | C120006 | Conical Bent Cartridge Ø 0.5 mm Ø 0.020 in | | Package 0603 QFP, IC | Stations: CDP, DIU, DDU, DMU Tools: AM120, PA120 |
| | C120004 | Conical Bent Cartridge Ø 0.7 mm S1 Ø 0.028 in | | SMD capacitors QFP, IC Through-hole | Stations: CDP, DIU, DDU, DMU Tools: AM120, PA120 |
| | C120012 | Conical Bent Cartridge Ø 0.7 mm S2 Ø 0.028 in | | SMD capacitors QFP, IC Through-hole Tip with an extra tinned surface | Stations: CDP, DIU, DDU, DMU Tools: AM120, PA120 |
| | C120011 | Chisel Bent Cartridge 0.6 x 0.3 mm 0.024 x 0.012 in | | Package 0603 | Stations: CDP, DIU, DDU, DMU Tools: AM120, PA120 |

C120 Cartridge Range for PA120 and AM120 Micro Tweezers

| | Ref. | Description | Image and dimensions | Suggested components | Compatible with |
|--|----------------|---|----------------------|-------------------------------|---|
| | C120013 | Blade Cartridge 2 mm 0.079 in | | LED SMD 2727, 1921, 1415 | Stations: CDP, DIU, DDU, DMU Tools: AM120, PA120 |
| | C120003 | Blade Cartridge 3 mm 0.118 in | | Package 1210, 1812 SO, SOT | Stations: CDP, DIU, DDU, DMU Tools: AM120, PA120 |
| | C120007 | Blade Cartridge 3.5 mm Right 0.138 in | | Package 1210, 1812 SO, SOT | Stations: CDP, DIU, DDU, DMU Tools: AM120, PA120 |
| | C120008 | Blade Cartridge 3.5 mm Left 0.138 in | | Package 1210, 1812 SO, SOT | Stations: CDP, DIU, DDU, DMU Tools: AM120, PA120 |
| | C120005 | Blade Cartridge 5 mm 0.197 in | | SO, SOT | Stations: CDP, DIU, DDU, DMU Tools: AM120, PA120 |
| | C120009 | Blade Cartridge 6 mm Right 0.236 in | | SO, SOT | Stations: CDP, DIU, DDU, DMU Tools: AM120, PA120 |
| | C120010 | Blade Cartridge 6 mm Left 0.236 in | | SO, SOT | Stations: CDP, DIU, DDU, DMU Tools: AM120, PA120 |

C210 Cartridge Range for T210 Precision Handles



| Ref. | Description | Image and dimensions | Suggested components | Compatible with |
|----------------|--|----------------------|--|--|
| C210020 | Conical Cartridge Ø 0.1 mm Ø 0.004 in | | Package 01005, 0201 Very fine pitch 0.4 mm QFP, IC | Stations: CDS, CDES, DIU, DDU, DMU Tools: T210, T210P, T210N |
| C210009 | Conical Cartridge Ø 0.2 mm Ø 0.008 in | | Package 01005, 0201 Very fine pitch 0.4mm QFP, IC | Stations: CDS, CDES, DIU, DDU, DMU Tools: T210, T210P, T210N |
| C210016 | Conical Cartridge Ø 0.3 mm S1 Ø 0.012 in | | Package 0201, 0402 Fine pitch 0.65 mm QFP, IC | Stations: CDS, CDES, DIU, DDU, DMU Tools: T210, T210P, T210N |
| C210001 | Conical Cartridge Ø 0.3 mm S2 Ø 0.012 in | | Package 0201, 0402 Fine pitch 0.65 mm QFP, IC | Stations: CDS, CDES, DIU, DDU, DMU Tools: T210, T210P, T210N |
| C210013 | Conical Cartridge Ø 0.5 mm Ø 0.020 in | | Package 0603 QFP, IC | Stations: CDS, CDES, DIU, DDU, DMU Tools: T210, T210P, T210N |
| C210003 | Conical Cartridge Ø 0.6 mm Ø 0.024 in | | General use | Stations: CDS, CDES, DIU, DDU, DMU Tools: T210, T210P, T210N |
| C210005 | Conical Cartridge Ø 1 mm Ø 0.039 in | | General use | Stations: CDS, CDES, DIU, DDU, DMU Tools: T210, T210P, T210N |

C210 Cartridge Range for T210 Precision Handles

| Ref. | Description | Image and dimensions | Suggested components | Compatible with |
|----------------|--|----------------------|---|--|
| C210002 | Conical Bent Cartridge Ø 0.2 mm Ø 0.008 in | | Package 0201, 0402 | Stations: CDS, CDES, DIU, DDU, DMU Tools: T210, T210P, T210N |
| C210010 | Conical Bent Cartridge Ø 0.3 mm Ø 0.012 in | | Package 0201, 0402 Fine pitch 0.65 mm QFP, IC | Stations: CDS, CDES, DIU, DDU, DMU Tools: T210, T210P, T210N |
| C210014 | Conical Bent Cartridge Ø 0.5 mm Ø 0.020 in | | Package 0603 QFP, IC | Stations: CDS, CDES, DIU, DDU, DMU Tools: T210, T210P, T210N |
| C210004 | Conical Bent Cartridge Ø 0.7 mm Ø 0.028 in | | General use | Stations: CDS, CDES, DIU, DDU, DMU Tools: T210, T210P, T210N |
| C210036 | Bevel Cartridge Ø 0.6 mm Ø 0.024 in | | Drag Soldering General use | Stations: CDS, CDES, DIU, DDU, DMU Tools: T210, T210P, T210N |
| C210006 | Bevel Cartridge Ø 1 mm Ø 0.039 in | | Drag Soldering General use | Stations: CD, CDE, DIU, DDU, DMU Tools: T210, T210P, T210N |
| C210027 | Bevel Cartridge Ø 1.5 mm Ø 0.059 in | | Drag Soldering General use | Stations: CDS, CDES, DIU, DDU, DMU Tools: T210, T210P, T210N |
| C210031 | Bevel Cartridge Ø 2 mm Ø 0.079 in | | Drag Soldering General use | Stations: CDS, CDES, DIU, DDU, DMU Tools: T210, T210P, T210N |

C210 Cartridge Range for T210 Precision Handles

| | Ref. | Description | Image and dimensions | Suggested components | Compatible with |
|--|----------------|--|----------------------|--|--|
| | C210028 | Spoon Cartridge Ø 1 mm Ø 0.039 in | | Drag soldering | Stations: CDS, CDES, DIU, DDU, DMU Tools: T210, T210P, T210N |
| | C210029 | Spoon Cartridge Ø 1.5 mm Ø 0.059 in | | Drag soldering | Stations: CDS, CDES, DIU, DDU, DMU Tools: T210, T210P, T210N |
| | C210030 | Spoon Cartridge Ø 2 mm Ø 0.079 in | | Drag soldering | Stations: CDS, CDES, DIU, DDU, DMU Tools: T210, T210P, T210N |
| | C210038 | Barrell Cartridge Ø 8 mm Ø 0.031 in | | Through-hole Cable soldering / desoldering | Stations: CDS, CDES, DIU, DDU, DMU Tools: T210 handles |
| | C210019 | Chisel Cartridge 0.2 x 0.1 mm 0.008 x 0.004 in | | Package 01005, 0201 Very fine pitch 0.4 mm QFP, IC | Stations: CDS, CDES, DIU, DDU, DMU Tools: T210, T210P, T210N |
| | C210023 | Chisel Cartridge 0.4 x 0.2 mm 0.016 x 0.008 in | | Package 0402 Very fine pitch 0.65 mm QFP, IC | Stations: CDS, CDES, DIU, DDU, DMU Tools: T210, T210P, T210N |
| | C210021 | Chisel Cartridge 0.6 x 0.3 mm 0.024 x 0.012 in | | Package 0603 | Stations: CDS, CDES, DIU, DDU, DMU Tools: T210, T210P, T210N |
| | C210024 | Chisel Cartridge 0.8 x 0.3 mm 0.032 x 0.012 in | | Package 0805 Through-hole | Stations: CDS, CDES, DIU, DDU, DMU Tools: T210, T210P, T210N |
| | C210022 | Chisel Cartridge 1.3 x 0.4 mm 0.051 x 0.016 in | | Package 0805 Through-hole | Stations: CDS, CDES, DIU, DDU, DMU Tools: T210, T210P, T210N |

C210 Cartridge Range for T210 Precision Handles

| | Ref. | Description | Image and dimensions | Suggested components | Compatible with |
|--|----------------|--|----------------------|--|--|
| | C210008 | Chisel Cartridge 1.3 x 0.6 mm 0.051 x 0.024 in | | Package 0805 Through-hole | Stations: CDS, CDES, DIU, DDU, DMU Tools: T210, T210P, T210N |
| | C210007 | Chisel Cartridge 2.3 x 0.7 mm 0.091 x 0.028 in | | Package 0805 Through-hole | Stations: CDS, CDES, DIU, DDU, DMU Tools: T210, T210P, T210N |
| | C210017 | Pin Cartridge Ø 0.7 mm Ø 0.028 in | | Through-hole | Stations: CDS, CDES, DIU, DDU, DMU Tools: T210, T210P, T210N |
| | C210015 | Pin/Connector Cartridge Ø 0.8 mm Ø 0.032 in | | Through-hole Coaxial connector | Stations: CDS, CDES, DIU, DDU, DMU Tools: T210, T210P, T210N |
| | C210025 | Pin/Connector Cartridge Ø 1.1 mm Ø 0.043 in | | Through-hole Coaxial connector | Stations: CDS, CDES, DIU, DDU, DMU Tools: T210, T210P, T210N |
| | C210012 | Pin/Wire Cartridge Ø 1 mm Ø 0.039 in | | Cables Connectors | Stations: CDS, CDES, DIU, DDU, DMU Tools: T210, T210P, T210N |
| | C210033 | Knife Cartridge 2.5 x 0.3 mm 0.098 x 0.012 in | | Drag soldering SMD SO, SOT Package 1210, 1812, 2010, 2512 | Stations: CD, CDE, DIU, DDU, DMU Tools: T210, T210P, T210N |
| | C210018 | Knife Cartridge 3.4 x 0.3 mm 0.134 x 0.012 in | | Drag soldering SMD SO, SOT Package 1210, 1812, 2010, 2512 | Stations: CDS, CDES, DIU, DDU, DMU Tools: T210, T210P, T210N |
| | C210034 | Conformal Coating Removal Steel Cartridge 1 x 0.1 mm 0.039 x 0.004 in | | Stainless Steel Remove underfill encapsulants | Stations: CDS, CDES, DIU, DDU, DMU Tools: T210, T210P, T210N |

C245 Cartridge Range for T245 General Purpose Handles



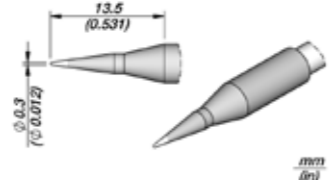
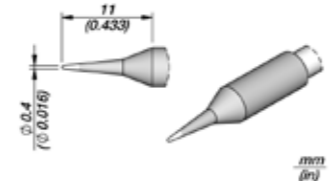
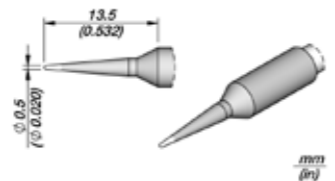
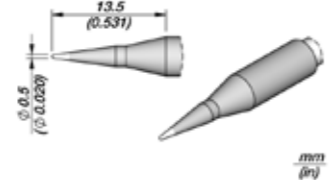
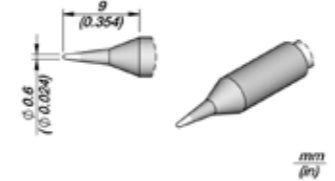
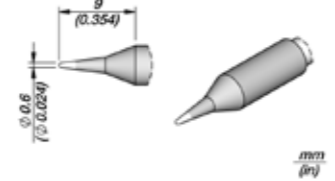
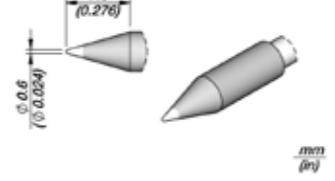

| | Ref. | Description | Image and dimensions | Suggested components | Compatible with |
|---|----------------|--|---|---|--|
|  | C245030 | Conical Cartridge Ø 0.3 mm Ø 0.012 in |  | Package 0201, 0402 Fine pitch 0.65 mm QFP, IC | Stations: CDB, CDEB, DIU, DDU, DMU Tools: T245, T245G, T245P, T245N |
| | C245032 | Conical Cartridge Ø 0.4 mm Ø 0.016 in |  | Package 0201, 0402 Fine pitch 0.65 mm QFP, IC | Stations: CDB, CDEB, DIU, DDU, DMU Tools: T245, T245G, T245P, T245N |
| | C245036 | Conical Cartridge Ø 0.5 mm S1 Ø 0.020 in |  | Package 0603 QFP, IC | Stations: CDB, CDEB, DIU, DDU, DMU Tools: T245, T245G, T245P, T245N |
| | C245930 | Conical Cartridge Ø 0.5 mm S2 Ø 0.020 in |  | Package 0603 QFP, IC | Stations: CDB, CDEB, DIU, DDU, DMU Tools: T245, T245G, T245P, T245N |
| | C245001 | Conical Cartridge Ø 0.6 mm Ø 0.024 in |  | Package 0603 QFP, IC | Stations: CDB, CDEB, DIU, DDU, DMU Tools: T245, T245G, T245P, T245N |
| | C245201 | Conical Cartridge Ø 0.6 mm L Ø 0.024 in |  | Package 0603 QFP, IC | Stations: CDB, CDEB, DIU, DDU, DMU Tools: T245, T245G, T245P, T245N |
| | C245937 | Conical Cartridge Ø 0.6 mm HT Ø 0.024 in |  | Package 0603 QFP, IC | Stations: CDB, CDEB, DIU, DDU, DMU Tools: T245, T245G, T245P, T245N |

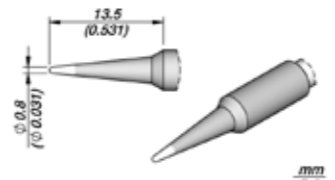
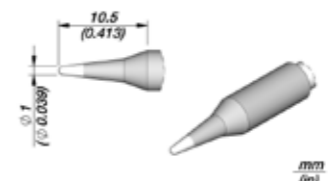
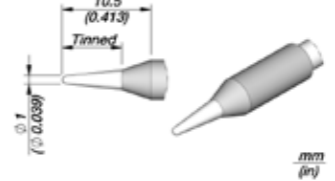
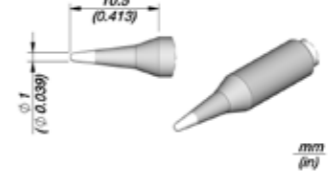
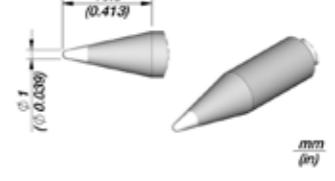
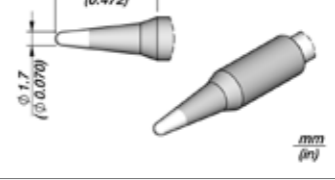
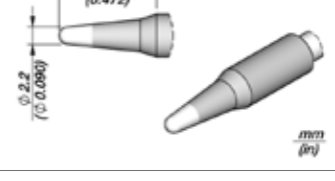
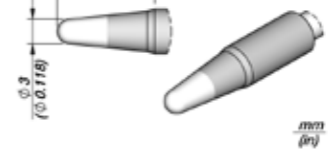

C245 Cartridge Range for T245 General Purpose Handles

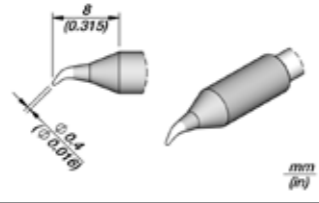
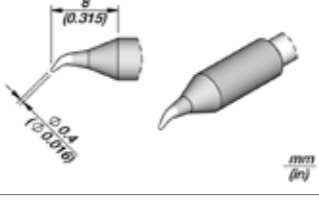
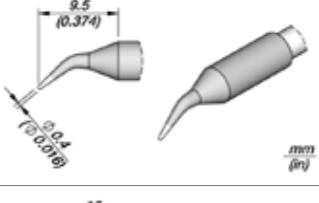
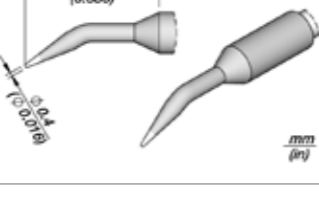
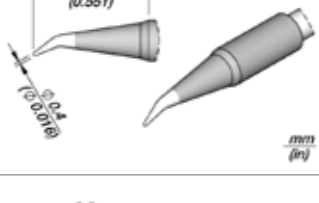
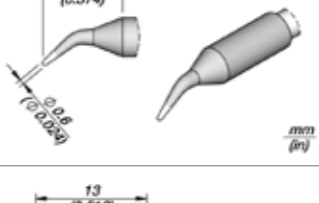
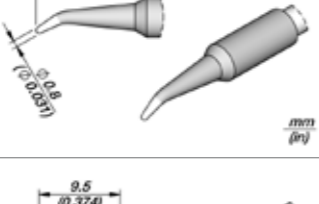
| | Ref. | Description | Image and dimensions | Suggested components | Compatible with |
|---|----------------|--|---|----------------------|---|
|  | C245957 | Conical Cartridge Ø 0.8 mm Ø 0.031 in |  | | Through-hole Stations: CDB, CDEB, DIU, DDU, DMU Tools: T245, T245G, T245P, T245N |
| | C245903 | Conical Cartridge Ø 1 mm S1 Ø 0.040 in |  | | General use Stations: CDB, CDEB, DIU, DDU, DMU Tools: T245, T245G, T245P, T245N |
| | C245041 | Conical Cartridge Ø 1 mm S2 Ø 0.040 in |  | | General use Tip with an extra tinned surface Stations: CDB, CDEB, DIU, DDU, DMU Tools: T245, T245G, T245P, T245N |
| | C245803 | Conical Cartridge Ø 1 mm L Ø 0.040 in |  | | General use Stations: CDB, CDEB, DIU, DDU, DMU Tools: T245, T245G, T245P, T245N |
| | C245403 | Conical Cartridge Ø 1 HT mm Ø 0.040 in |  | | General use Stations: CDB, CDEB, DIU, DDU, DMU Tools: T245, T245G, T245P, T245N |
| | C245943 | Conical Cartridge Ø 1.7 mm Ø 0.070 in |  | | General use Stations: CDB, CDEB, DIU, DDU, DMU Tools: T245, T245G, T245P, T245N |
| | C245933 | Conical Cartridge Ø 2.2 mm Ø 0.090 in |  | | General use Stations: CDB, CDEB, DIU, DDU, DMU Tools: T245, T245G, T245P, T245N |
| | C245107 | Conical Cartridge Ø 3 mm HT Ø 0.118 in |  | | General use Stations: CDB, CDEB, DIU, DDU, DMU Tools: T245, T245G, T245P, T245N |

C245 Cartridge Range for T245 General Purpose Handles

| Ref. | Description | Image and dimensions | Suggested components | Compatible with |
|----------------|---|---|---|--|
| C245034 | Conical Bent Cartridge Ø 0.4 mm S1 Ø 0.016 in |  | Package 0201, 0402 Fine pitch 0.65 mm QFP, IC | Stations: CDB, CDEB, DIU, DDU, DMU Tools: T245, T245G, T245P, T245N |
| C245234 | Conical Bent Cartridge Ø 0.4 mm S1 L Ø 0.016 in |  | Package 0201, 0402 Fine pitch 0.65 mm QFP, IC | Stations: CDB, CDEB, DIU, DDU, DMU Tools: T245, T245G, T245P, T245N |
| C245029 | Conical Bent Cartridge Ø 0.4 mm S2 Ø 0.016 in |  | Package 0201, 0402 Fine pitch 0.65 mm QFP, IC | Stations: CDB, CDEB, DIU, DDU, DMU Tools: T245, T245G, T245P, T245N |
| C245126 | Conical Bent Cartridge Ø 0.4 mm S3 Ø 0.016 in |  | Package 0201, 0402 Fine pitch 0.65 mm QFP, IC | Stations: CDB, CDEB, DIU, DDU, DMU Tools: T245, T245G, T245P, T245N |
| C245786 | Conical Bent Cartridge Ø 0.4 mm S4 Ø 0.016 in |  | Package 0201, 0402 Fine pitch 0.65 mm QFP, IC | Stations: CDB, CDEB, DIU, DDU, DMU Tools: T245, T245G, T245P, T245N |
| C245929 | Conical Bent Cartridge Ø 0.6 mm Ø 0.024 in |  | Package 0603 QFP, IC | Stations: CDB, CDEB, DIU, DDU, DMU Tools: T245, T245G, T245P, T245N |
| C245935 | Conical Bent Cartridge Ø 0.8 mm Ø 0.031 in |  | Through-hole | Stations: CDB, CDEB, DIU, DDU, DMU Tools: T245, T245G, T245P, T245N |
| C245904 | Conical Bent Cartridge Ø 1 mm Ø 0.039 in |  | General use | Stations: CDB, CDEB, DIU, DDU, DMU Tools: T245, T245G, T245P, T245N |

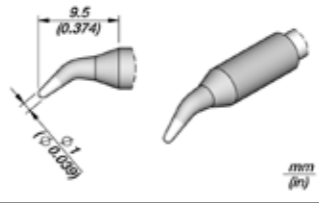
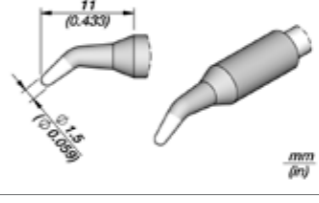
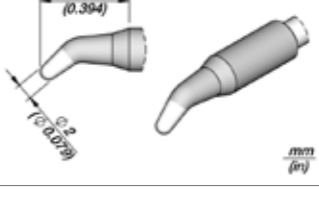
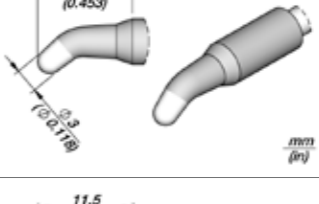
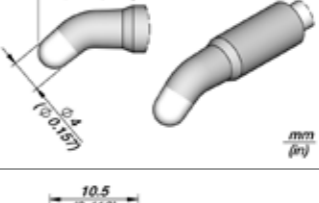
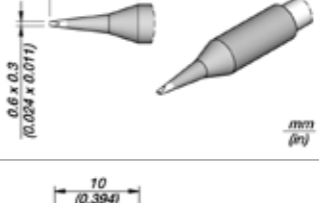
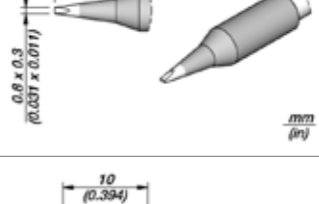
C245 Cartridge Range for T245 General Purpose Handles

| Ref. | Description | Image and dimensions | Suggested components | Compatible with |
|----------------|--|---|------------------------------|--|
| C245804 | Conical Bent Cartridge Ø 1 mm L Ø 0.039 in |  | General use | Stations: CDB, CDEB, DIU, DDU, DMU Tools: T245, T245G, T245P, T245N |
| C245259 | Conical Bent Cartridge Ø 1.5 mm Ø 0.059 in |  | General use | Stations: CDB, CDEB, DIU, DDU, DMU Tools: T245, T245G, T245P, T245N |
| C245260 | Conical Bent Cartridge Ø 2 mm HT Ø 0.079 in |  | General use | Stations: CDB, CDEB, DIU, DDU, DMU Tools: T245, T245G, T245P, T245N |
| C245627 | Conical Bent Cartridge Ø 3 mm Ø 0.118 in |  | General use | Stations: CDB, CDEB, DIU, DDU, DMU Tools: T245, T245G, T245P, T245N |
| C245628 | Conical Bent Cartridge Ø 4 mm HT Ø 0.157 in |  | General use | Stations: CDB, CDEB, DIU, DDU, DMU Tools: T245, T245G, T245P, T245N |
| C245731 | Chisel Cartridge 0.6 x 0.3 mm 0.024 x 0.011 in |  | Package 0603 | Stations: CDB, CDEB, DIU, DDU, DMU Tools: T245, T245G, T245P, T245N |
| C245773 | Chisel Cartridge 0.8 x 0.3 mm 0.031 x 0.011 in |  | Package 0805 Through-hole | Stations: CDB, CDEB, DIU, DDU, DMU Tools: T245, T245G, T245P, T245N |
| C245673 | Chisel Cartridge 0.8 x 0.3 mm L 0.031 x 0.011 in |  | Package 0805 Through-hole | Stations: CDB, CDEB, DIU, DDU, DMU Tools: T245, T245G, T245P, T245N |

C245 Cartridge Range for T245 General Purpose Handles

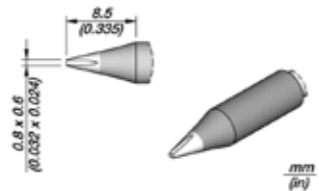
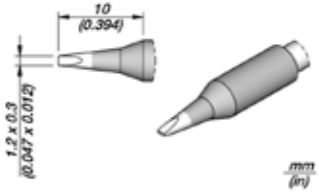
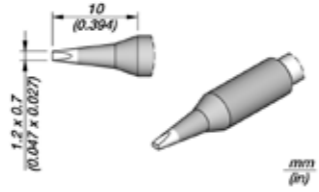
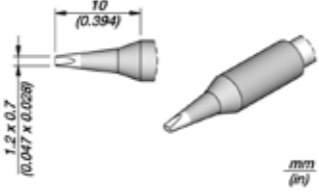
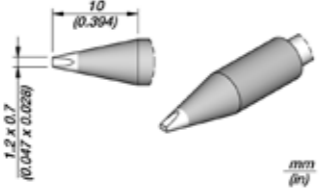
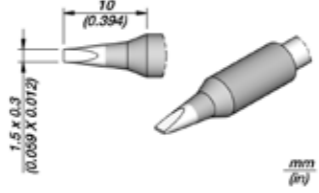
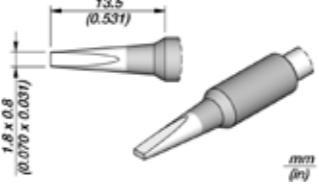
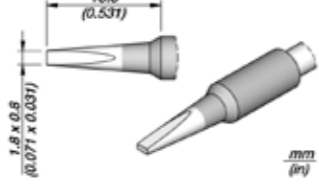
| Ref. | Description | Image and dimensions | Suggested components | Compatible with |
|----------------|---|---|------------------------------|--|
| C245742 | Chisel Cartridge 0.8 x 0.6 mm HT 0.032 x 0.024 in |  | Package 0805 Through-hole | Stations: CDB, CDEB, DIU, DDU, DMU Tools: T245, T245G, T245P, T245N |
| C245774 | Chisel Cartridge 1.2 x 0.3 mm 0.047 x 0.012 in |  | General use | Stations: CDB, CDEB, DIU, DDU, DMU Tools: T245, T245G, T245P, T245N |
| C245906 | Chisel Cartridge 1.2 x 0.7 mm 0.047 x 0.027 in |  | General use | Stations: CDB, CDEB, DIU, DDU, DMU Tools: T245, T245G, T245P, T245N |
| C245806 | Chisel Cartridge 1.2 x 0.7 mm L 0.047 x 0.028 in |  | General use | Stations: CDB, CDEB, DIU, DDU, DMU Tools: T245, T245G, T245P, T245N |
| C245406 | Chisel Cartridge 1.2 x 0.7 mm HT 0.047 x 0.028 in |  | General use | Stations: CDB, CDEB, DIU, DDU, DMU Tools: T245, T245G, T245P, T245N |
| C245768 | Chisel Cartridge 1.5 x 0.3 mm 0.059 x 0.012 in |  | General use | Stations: CDB, CDEB, DIU, DDU, DMU Tools: T245, T245G, T245P, T245N |
| C245944 | Chisel Cartridge 1.8 x 0.8 mm 0.070 x 0.031 in |  | General use | Stations: CDB, CDEB, DIU, DDU, DMU Tools: T245, T245G, T245P, T245N |
| C245844 | Chisel Cartridge 1.8 x 0.8 mm L 0.071 x 0.031 in |  | General use | Stations: CDB, CDEB, DIU, DDU, DMU Tools: T245, T245G, T245P, T245N |

C245 Cartridge Range for T245 General Purpose Handles

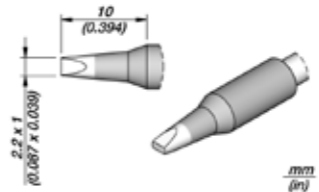
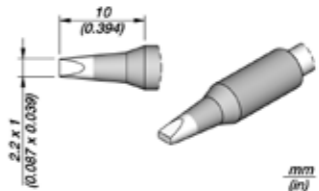
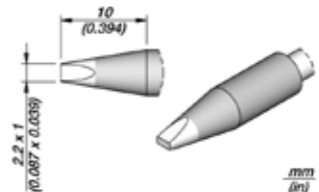
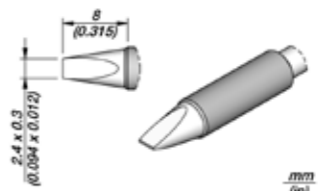
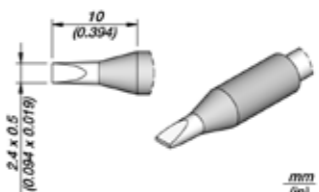
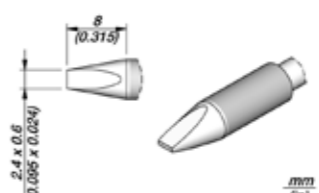
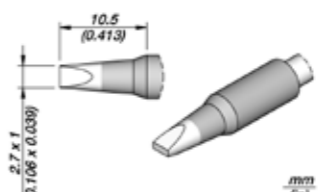
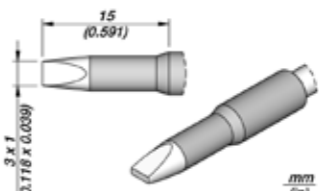
| Ref. | Description | Image and dimensions | Suggested components | Compatible with |
|----------------|---|---|----------------------|--|
| C245907 | Chisel Cartridge 2.2 x 1 mm 0.087 x 0.039 in |  | General use | Stations: CDB, CDEB, DIU, DDU, DMU Tools: T245, T245G, T245P, T245N |
| C245807 | Chisel Cartridge 2.2 x 1 mm L 0.087 x 0.039 in |  | General use | Stations: CDB, CDEB, DIU, DDU, DMU Tools: T245, T245G, T245P, T245N |
| C245407 | Chisel Cartridge 2.2 x 1 mm HT 0.087 x 0.039 in |  | General use | Stations: CDB, CDEB, DIU, DDU, DMU Tools: T245, T245G, T245P, T245N |
| C245770 | Chisel Cartridge 2.4 x 0.3 mm 0.094 x 0.012 in |  | General use | Stations: CDB, CDEB, DIU, DDU, DMU Tools: T245, T245G, T245P, T245N |
| C245759 | Chisel Cartridge 2.4 x 0.5 mm HT 0.094 x 0.019 in |  | General use | Stations: CDB, CDEB, DIU, DDU, DMU Tools: T245, T245G, T245P, T245N |
| C245741 | Chisel Cartridge 2.4 x 0.6 mm HT 0.095 x 0.024 in |  | General use | Stations: CDB, CDEB, DIU, DDU, DMU Tools: T245, T245G, T245P, T245N |
| C245729 | Chisel Cartridge 2.7 x 1 mm 0.106 x 0.039 in |  | General use | Stations: CDB, CDEB, DIU, DDU, DMU Tools: T245, T245G, T245P, T245N |
| C245061 | Chisel Cartridge 3 x 1 mm 0.118 x 0.039 in |  | General use | Stations: CDB, CDEB, DIU, DDU, DMU Tools: T245, T245G, T245P, T245N |

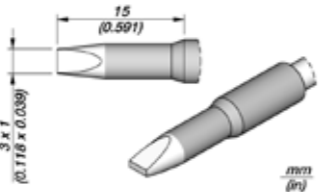
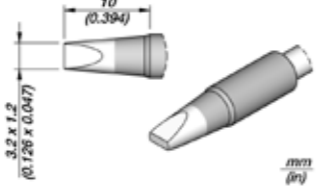
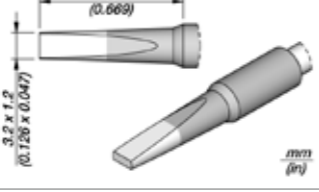
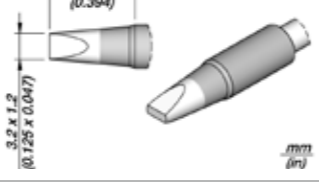
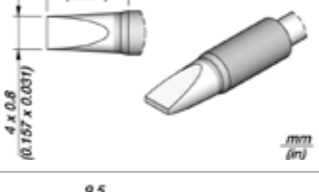
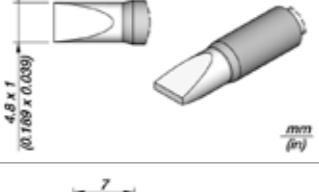
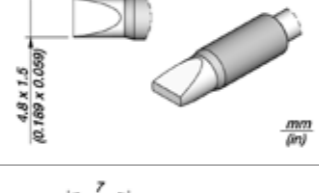
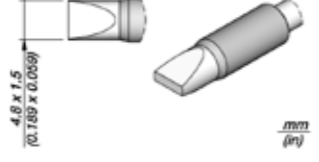

C245 Cartridge Range for T245 General Purpose Handles

| Ref. | Description | Image and dimensions | Suggested components | Compatible with |
|----------------|--|---|----------------------|--|
| C245261 | Chisel Cartridge 3 x 1 mm L 0.118 x 0.039 in |  | General use | Stations: CDB, CDEB, DIU, DDU, DMU Tools: T245, T245G, T245P, T245N |
| C245911 | Chisel Cartridge 3.2 x 1.2 mm 0.126 x 0.047 in |  | General use | Stations: CDB, CDEB, DIU, DDU, DMU Tools: T245, T245G, T245P, T245N |
| C245775 | Chisel Cartridge 3.2 x 1.2 mm S1 0.126 x 0.047 in |  | General use | Stations: CDB, CDEB, DIU, DDU, DMU Tools: T245, T245G, T245P, T245N |
| C245811 | Chisel Cartridge 3.2 x 1.2 mm L 0.125 x 0.047 in |  | General use | Stations: CDB, CDEB, DIU, DDU, DMU Tools: T245, T245G, T245P, T245N |
| C245755 | Chisel Cartridge 4 x 0.8 mm HT 0.157 x 0.031 in |  | General use | Stations: CDB, CDEB, DIU, DDU, DMU Tools: T245, T245G, T245P, T245N |
| C245756 | Chisel Cartridge 4.8 x 1 mm HT 0.189 x 0.0374 in |  | General use | Stations: CDB, CDEB, DIU, DDU, DMU Tools: T245, T245G, T245P, T245N |
| C245908 | Chisel Cartridge 4.8 x 1.5 mm HT S1 0.189 x 0.059 in |  | General use | Stations: CDB, CDEB, DIU, DDU, DMU Tools: T245, T245G, T245P, T245N |
| C245808 | Chisel Cartridge 4.8 x 1.5 mm HT L 0.189 x 0.059 in |  | General use | Stations: CDB, CDEB, DIU, DDU, DMU Tools: T245, T245G, T245P, T245N |

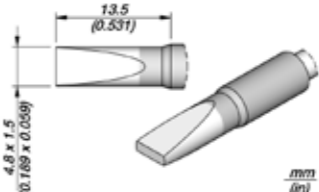
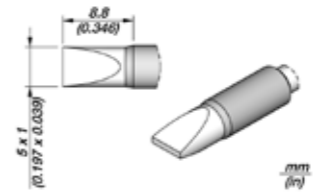
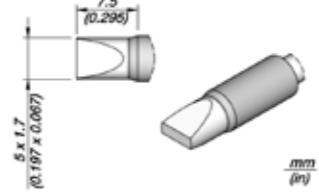
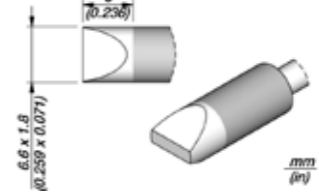
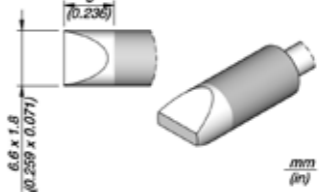
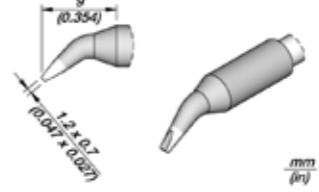
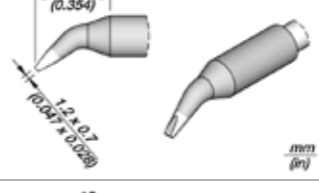
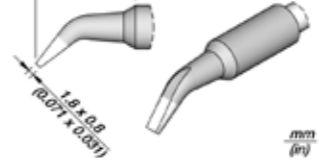
C245 Cartridge Range for T245 General Purpose Handles

| Ref. | Description | Image and dimensions | Suggested components | Compatible with |
|----------------|---|---|----------------------|--|
| C245708 | Chisel Cartridge 4.8 x 1.5 mm HT S2 0.189 x 0.059 in |  | General use | Stations: CDB, CDEB, DIU, DDU, DMU Tools: T245, T245G, T245P, T245N |
| C245967 | Chisel Cartridge 5 x 1 mm HT 0.197 x 0.039 in |  | General use | Stations: CDB, CDEB, DIU, DDU, DMU Tools: T245, T245G, T245P, T245N |
| C245069 | Chisel Cartridge 5 x 1.7 mm HT 0.197 x 0.067 in |  | General use | Stations: CDB, CDEB, DIU, DDU, DMU Tools: T245, T245G, T245P, T245N |
| C245966 | Chisel Cartridge 6.6 x 1.8 mm HT 0.259 x 0.071 in |  | General use | Stations: CDB, CDEB, DIU, DDU, DMU Tools: T245, T245G, T245P, T245N |
| C245866 | Chisel Cartridge 6.6 x 1.8 mm HT L 0.259 x 0.071 in |  | General use | Stations: CDB, CDEB, DIU, DDU, DMU Tools: T245, T245G, T245P, T245N |
| C245962 | Chisel Bent Cartridge 1.2 x 0.7 mm 0.047 x 0.027 in |  | General use | Stations: CDB, CDEB, DIU, DDU, DMU Tools: T245, T245G, T245P, T245N |
| C245862 | Chisel Bent Cartridge 1.2 x 0.7 mm L 0.047 x 0.028 in |  | General use | Stations: CDB, CDEB, DIU, DDU, DMU Tools: T245, T245G, T245P, T245N |
| C245963 | Chisel Bent Cartridge 1.8 x 0.8 mm 0.071 x 0.031 in |  | General use | Stations: CDB, CDEB, DIU, DDU, DMU Tools: T245, T245G, T245P, T245N |

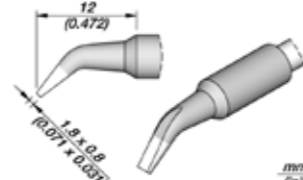
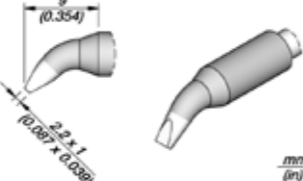
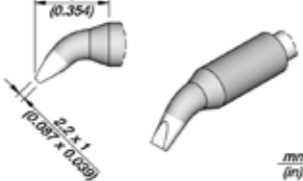
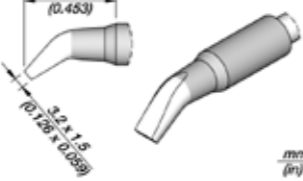
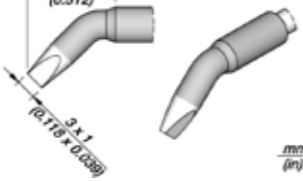
C245 Cartridge Range for T245 General Purpose Handles

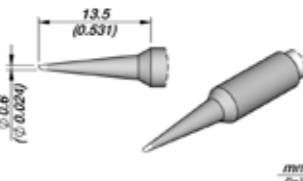
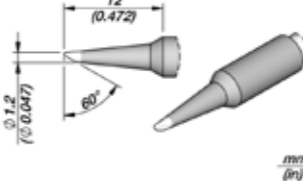
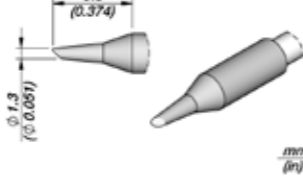
| | Ref. | Description | Image and dimensions | Suggested components | Compatible with |
|---|----------------|---|---|--|--|
|  | C245863 | Chisel Bent Cartridge 1.8 x 0.8 mm L 0.071 x 0.031 in |  | General use | Stations: CDB, CDEB, DIU, DDU, DMU Tools: T245, T245G, T245P, T245N |
| | C245946 | Chisel Bent Cartridge 2.2 x 1 mm 0.087 x 0.039 in |  | General use | Stations: CDB, CDEB, DIU, DDU, DMU Tools: T245, T245G, T245P, T245N |
| | C245846 | Chisel Bent Cartridge 2.2 x 1 mm L 0.087 x 0.039 in |  | General use | Stations: CDB, CDEB, DIU, DDU, DMU Tools: T245, T245G, T245P, T245N |
| | C245732 | Chisel Bent Cartridge 3.2 x 1.5 mm 0.126 x 0.059 in |  | General use | Stations: CDB, CDEB, DIU, DDU, DMU Tools: T245, T245G, T245P, T245N |
| | C245761 | Chisel Bent Cartridge 3 x 1 mm 0.118 x 0.039 in |  | General use | Stations: CDB, CDEB, DIU, DDU, DMU Tools: T245, T245G, T245P, T245N |
|  | C245747 | Bevel Cartridge Ø 0.6 mm Ø 0.024 in |  | Package 0603 Through-hole | Stations: CDB, CDEB, DIU, DDU, DMU Tools: T245, T245G, T245P, T245N |
| | C245710 | Bevel Cartridge Ø 1.2 mm Ø 0.047 in |  | Drag soldering Through-hole | Stations: CDB, CDEB, DIU, DDU, DMU Tools: T245, T245G, T245P, T245N |
| | C245064 | Bevel Cartridge Ø 1.3 mm Ø 0.051 in |  | Drag soldering Through-hole Hoof tip with reduced tinned surface, ideal for touch-up | Stations: CDB, CDEB, DIU, DDU, DMU Tools: T245, T245G, T245P, T245N |



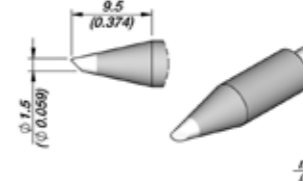
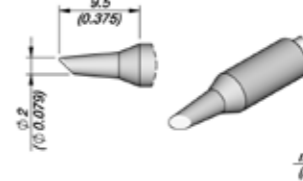

C245 Cartridge Range for T245 General Purpose Handles

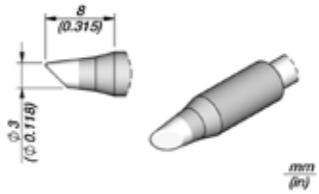
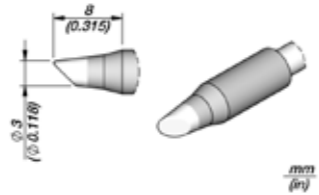
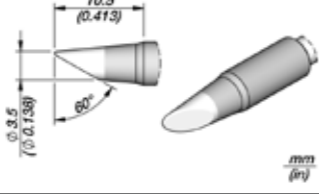
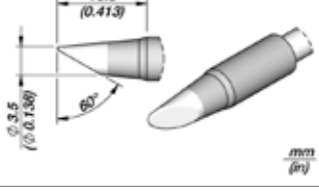
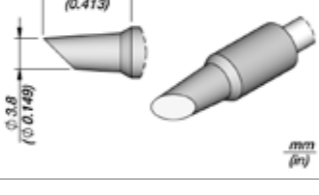
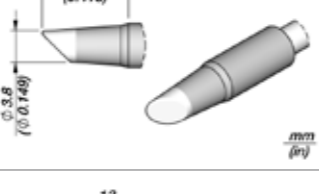
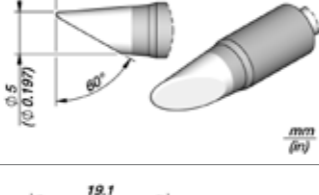
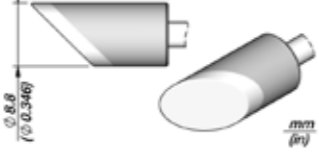
| | Ref. | Description | Image and dimensions | Suggested components | Compatible with |
|---|----------------|---|---|--|--|
|  | C245905 | Bevel Cartridge Ø 1.5 mm Ø 0.059 in |  | Drag soldering Through-hole | Stations: CDB, CDEB, DIU, DDU, DMU Tools: T245, T245G, T245P, T245N |
| | C245405 | Bevel Cartridge Ø 1.5 mm HT Ø 0.059 in |  | Drag soldering Through-hole | Stations: CDB, CDEB, DIU, DDU, DMU Tools: T245, T245G, T245P, T245N |
| | C245102 | Bevel Cartridge Ø 2 mm Ø 0.079 in |  | Drag soldering Through-hole Hoof tip with reduced tinned surface, ideal for touch-up | Stations: CDB, CDEB, DIU, DDU, DMU Tools: T245, T245G, T245P, T245N |
| | C245945 | Bevel Cartridge Ø 2.2 mm Ø 0.087 in |  | Drag soldering Through-hole | Stations: CDB, CDEB, DIU, DDU, DMU Tools: T245, T245G, T245P, T245N |
| | C245845 | Bevel Cartridge Ø 2.2 mm L Ø 0.087 in |  | Drag soldering Through-hole | Stations: CDB, CDEB, DIU, DDU, DMU Tools: T245, T245G, T245P, T245N |
| | C245795 | Bevel Cartridge Ø 2.5 mm L Ø 0.098 in |  | Drag soldering Through-hole | Stations: CDB, CDEB, DIU, DDU, DMU Tools: T245, T245G, T245P, T245N |
| | C245784 | Bevel Cartridge Ø 2.8 mm Ø 0.110 in |  | Drag soldering Through-hole | Stations: CDB, CDEB, DIU, DDU, DMU Tools: T245, T245G, T245P, T245N |
| | C245793 | Bevel Cartridge Ø 2.8 mm - 60° Ø 0.110 in - 60° |  | Drag soldering Through-hole | Stations: CDB, CDEB, DIU, DDU, DMU Tools: T245, T245G, T245P, T245N |



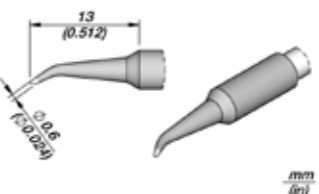
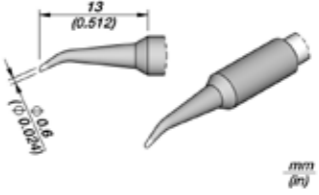

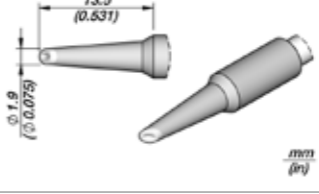
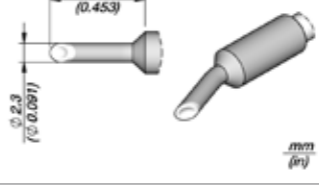
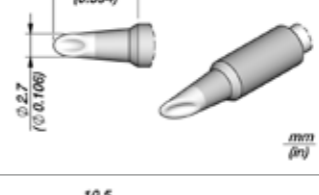
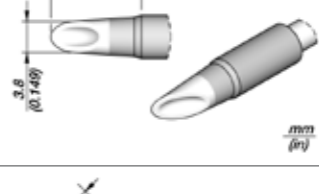
C245 Cartridge Range for T245 General Purpose Handles

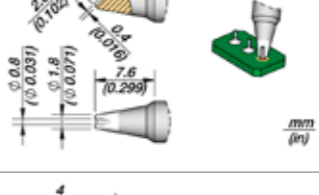
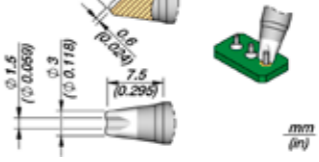
| | Ref. | Description | Image and dimensions | Suggested components | Compatible with |
|---|----------------|--|---|--|--|
|  | C245912 | Bevel Cartridge Ø 3 mm Ø 0.118 in |  | Drag soldering Through-hole | Stations: CDB, CDEB, DIU, DDU, DMU Tools: T245, T245G, T245P, T245N |
| | C245812 | Bevel Cartridge Ø 3 mm L Ø 0.118 in |  | Drag soldering Through-hole | Stations: CDB, CDEB, DIU, DDU, DMU Tools: T245, T245G, T245P, T245N |
| | C245056 | Bevel Cartridge Ø 3.5 mm HT Ø 0.138 in |  | Drag soldering Through-hole | Stations: CDB, CDEB, DIU, DDU, DMU Tools: T245, T245G, T245P, T245N |
| | C245256 | Bevel Cartridge Ø 3.5 mm HT L Ø 0.138 in |  | Drag soldering Through-hole | Stations: CDB, CDEB, DIU, DDU, DMU Tools: T245, T245G, T245P, T245N |
| | C245797 | Bevel Cartridge Ø 3.8 mm Ø 0.149 in |  | Hoof Tip with reduced tinned surface, ideal for touch-up | Stations: CDB, CDEB, DIU, DDU, DMU Tools: T245, T245G, T245P, T245N |
| | C245951 | Bevel Cartridge Ø 3.8 mm HT Ø 0.149 in |  | Drag soldering Through-hole | Stations: CDB, CDEB, DIU, DDU, DMU Tools: T245, T245G, T245P, T245N |
| | C245766 | Bevel Cartridge Ø 5 mm Ø 0.197 in |  | Wide area | Stations: CDB, CDEB, DIU, DDU, DMU Tools: T245, T245G, T245P, T245N |
| | C245301 | Bevel Cartridge Ø 8 mm Ø 0.346 in |  | Wide area | Stations: CDB, CDEB, DIU, DDU, DMU Tools: T245, T245G, T245P, T245N |

C245 Cartridge Range for T245 General Purpose Handles

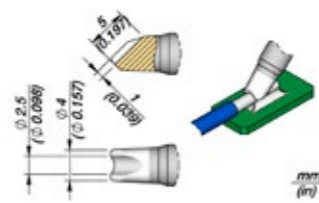
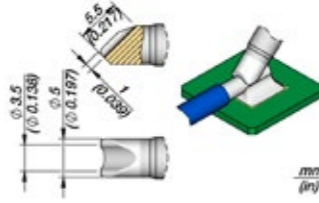
| | Ref. | Description | Image and dimensions | Suggested components | Compatible with |
|---|----------------|---|---|----------------------------------|--|
|  | C245748 | Bevel Bent Cartridge Ø 0.6 mm S1 Ø 0.024 in |  | Package 0603 Through-hole | Stations: CDB, CDEB, DIU, DDU, DMU Tools: T245, T245G, T245P, T245N |
| | C245749 | Bevel Bent Cartridge Ø 0.6 mm S2 Ø 0.024 in |  | Package 0603 Through-hole | Stations: CDB, CDEB, DIU, DDU, DMU Tools: T245, T245G, T245P, T245N |
|  | C245965 | Spoon Cartridge Ø 1.9 mm Ø 0.075 in |  | Drag soldering | Stations: CDB, CDEB, DIU, DDU, DMU Tools: T245, T245G, T245P, T245N |
| | C245067 | Spoon Cartridge Ø 2.3 mm Ø 0.091 in |  | Drag soldering | Stations: CDB, CDEB, DIU, DDU, DMU Tools: T245, T245G, T245P, T245N |
| | C245931 | Spoon Cartridge Ø 2.7 mm Ø 0.106 in |  | Drag soldering | Stations: CDB, CDEB, DIU, DDU, DMU Tools: T245, T245G, T245P, T245N |
| | C245938 | Spoon Cartridge Ø 3.8 mm Ø 0.149 in |  | Drag soldering | Stations: CDB, CDEB, DIU, DDU, DMU Tools: T245, T245G, T245P, T245N |
|  | C245790 | Barrel Cartridge Ø 0.8 mm Ø 0.031 in |  | Through-hole Cable sold/desol | Stations: CDB, CDEB, DIU, DDU, DMU Tools: T245, T245G, T245P, T245N |
| | C245785 | Barrel Cartridge Ø 1.5 mm Ø 0.059 in |  | Through-hole Cable sold/desol | Stations: CDB, CDEB, DIU, DDU, DMU Tools: T245, T245G, T245P, T245N |

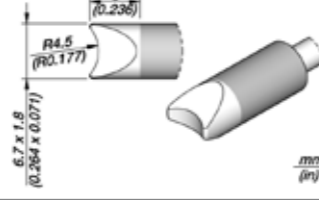
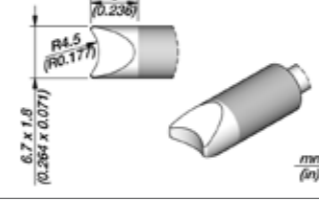
C245 Cartridge Range for T245 General Purpose Handles

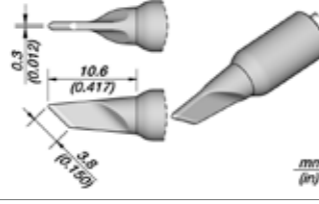
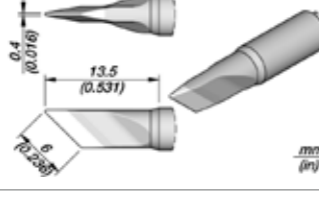
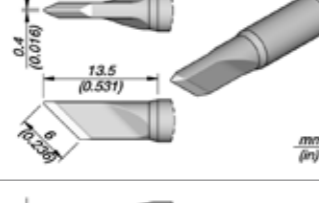
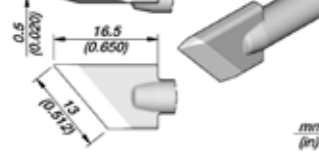
| | Ref. | Description | Image and dimensions | Suggested components | Compatible with |
|---|----------------|---|---|---|--|
|  | C245763 | Pin/Connector Cartridge Ø 2.5 mm Ø 0.098 in |  | Through-hole Cable sold/desol | Stations: CDB, CDEB, DIU, DDU, DMU Tools: T245, T245G, T245P, T245N |
| | C245760 | Pin/Connector Cartridge Ø 3.5 mm Ø 0.138 in |  | Through-hole Cable sold/desol | Stations: CDB, CDEB, DIU, DDU, DMU Tools: T245, T245G, T245P, T245N |
|  | C245762 | Pin/Connector Cartridge R. 4.5 mm R. 0.177 in |  | Cable sold/desol | Stations: CDB, CDEB, DIU, DDU, DMU Tools: T245, T245G, T245P, T245N |
| | C245662 | Round Connector Cartridge R. 4.5 mm L R. 0.177 in |  | Cable sold/desol | Stations: CDB, CDEB, DIU, DDU, DMU Tools: T245, T245G, T245P, T245N |
|  | C245789 | Knife Cartridge 3.8 x 0.3 mm 0.150 x 0.012 in |  | Drag soldering | Stations: CDB, CDEB, DIU, DDU, DMU Tools: T245, T245G, T245P, T245N |
| | C245939 | Knife Cartridge 6.0 x 0.4 mm 0.236 x 0.016 in |  | Drag soldering | Stations: CDB, CDEB, DIU, DDU, DMU Tools: T245, T245G, T245P, T245N |
| | C245765 | Knife Cartridge 6.0 x 0.4 mm S1 0.236 x 0.016 in |  | Drag soldering | Stations: CDB, CDEB, DIU, DDU, DMU Tools: T245, T245G, T245P, T245N |
| | C245955 | Knife Cartridge 13 x 0.5 mm 0.512 x 0.020 in |  | Drag Soldering Connector desoldering | Stations: CDB, CDEB, DIU, DDU, DMU Tools: T245, T245G, T245P, T245N |

C245 Cartridge Range for T245 General Purpose Handles

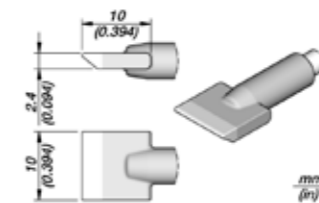
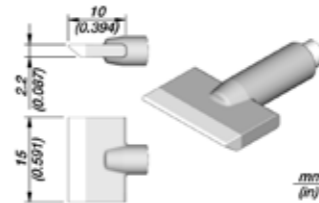
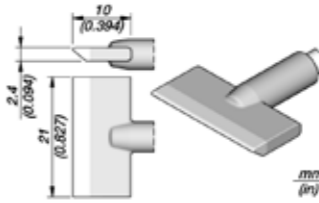
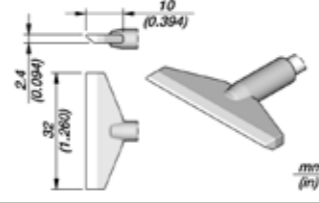
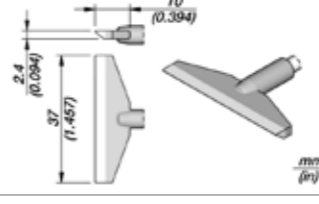
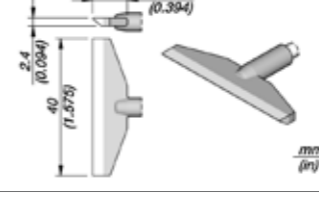
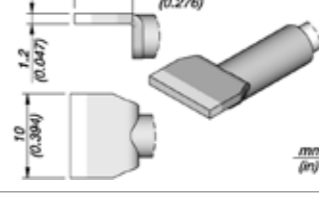
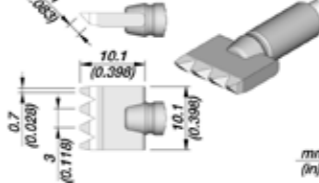
| | Ref. | Description | Image and dimensions | Suggested components | Compatible with |
|---|----------------|---|---|---------------------------------------|--|
|  | C245914 | Blade Cartridge 10 mm S1 0.394 in |  | Pad cleaning Connector desoldering | Stations: CDB, CDEB, DIU, DDU, DMU Tools: T245, T245G, T245P, T245N |
| | C245752 | Blade Cartridge 15 mm 0.591 in |  | Pad cleaning Connector desoldering | Stations: CDB, CDEB, DIU, DDU, DMU Tools: T245, T245G, T245P, T245N |
| | C245913 | Blade Cartridge 21 mm 0.827 in |  | Pad cleaning Connector desoldering | Stations: CDB, CDEB, DIU, DDU, DMU Tools: T245, T245G, T245P, T245N |
| | C245949 | Blade Cartridge 32 mm 1.260 in |  | Pad cleaning Connector desoldering | Stations: CDB, CDEB, DIU, DDU, DMU Tools: T245, T245G, T245P, T245N |
| | C245776 | Blade Cartridge 37 mm 1.457 in |  | Pad cleaning Connector desoldering | Stations: CDB, CDEB, DIU, DDU, DMU Tools: T245, T245G, T245P, T245N |
| | C245792 | Blade Cartridge 40 mm 1.575 in |  | Pad cleaning Connector desoldering | Stations: CDB, CDEB, DIU, DDU, DMU Tools: T245, T245G, T245P, T245N |
| | C245730 | Blade Cartridge 10 mm S2 0.394 in |  | Pad cleaning Connector desoldering | Stations: CDB, CDEB, DIU, DDU, DMU Tools: T245, T245G, T245P, T245N |
| | C245728 | Multipad Blade Cartridge 10.1 mm 0.398 in |  | Connector sold / desold | Stations: CDB, CDEB, DIU, DDU, DMU Tools: T245, T245G, T245P, T245N |

C245 Cartridge Range for T245 General Purpose Handles

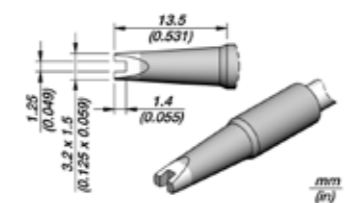
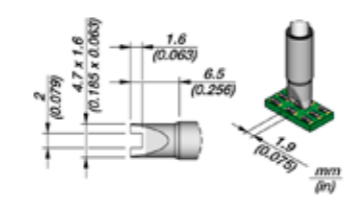
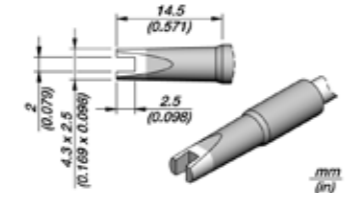
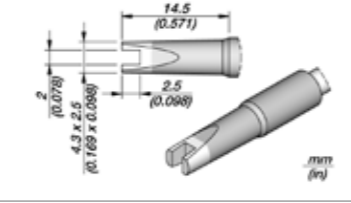
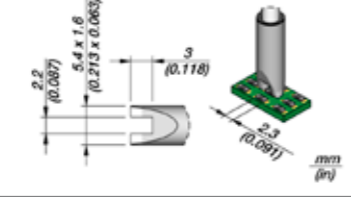
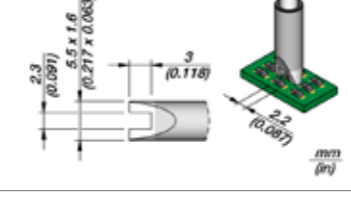
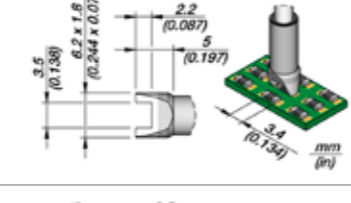
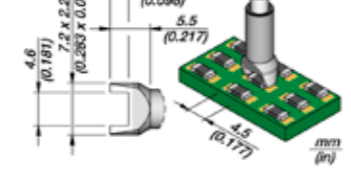
| Ref. | Description | Image and dimensions | Suggested components | Compatible with |
|----------------|---|---|---------------------------------|--|
| C245757 | Chip Cartridge 1.25 mm 0.049 in |  | SMD resistors SMD capacitors | Stations: CDB, CDEB, DIU, DDU, DMU Tools: T245, T245G, T245P, T245N |
| C245016 | Chip Cartridge 1.9 mm 0.075 in |  | SMD resistors SMD capacitors | Stations: CDB, CDEB, DIU, DDU, DMU Tools: T245, T245G, T245P, T245N |
| C245758 | Chip Cartridge 2 mm 0.079 in |  | SMD resistors SMD capacitors | Stations: CDB, CDEB, DIU, DDU, DMU Tools: T245, T245G, T245P, T245N |
| C245658 | Chip Cartridge 2.0 mm L 0.078 in |  | SMD resistors SMD capacitors | Stations: CDB, CDEB, DIU, DDU, DMU Tools: T245, T245G, T245P, T245N |
| C245017 | Chip Cartridge 2.3 mm S1 0.091 in |  | SMD resistors SMD capacitors | Stations: CDB, CDEB, DIU, DDU, DMU Tools: T245, T245G, T245P, T245N |
| C245150 | Chip Cartridge 2.2 mm S2 0.087 in |  | SMD resistors SMD capacitors | Stations: CDB, CDEB, DIU, DDU, DMU Tools: T245, T245G, T245P, T245N |
| C245018 | Chip Cartridge 3.4 mm 0.134 in |  | SMD resistors SMD capacitors | Stations: CD, CDE, DIU, DDU, DMU Tools: T245, T245G, T245P, T245N |
| C245019 | Chip Cartridge 4.5 mm 0.177 in |  | SMD resistors SMD capacitors | Stations: CDB, CDEB, DIU, DDU, DMU Tools: T245, T245G, T245P, T245N |

C245 Cartridge Range for T245 General Purpose Handles

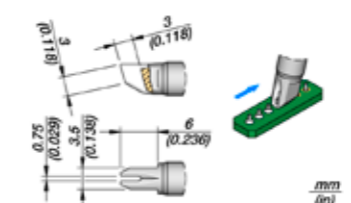
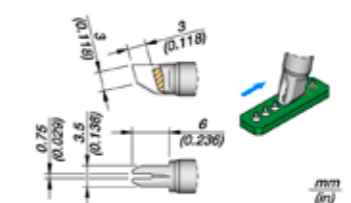
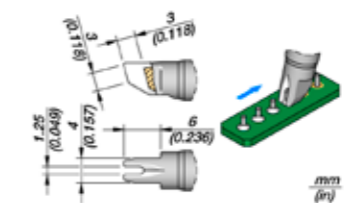
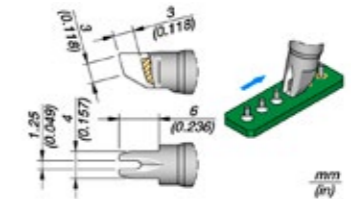
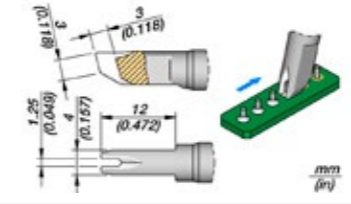
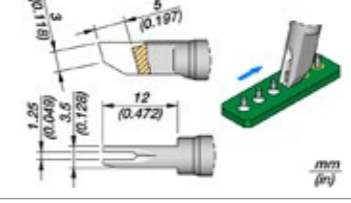
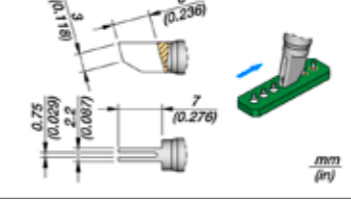
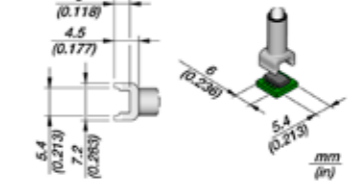
| Ref. | Description | Image and dimensions | Suggested components | Compatible with |
|----------------|---|---|----------------------|--|
| C245754 | Drag Cartridge 0.75 mm 0.029 in |  | Drag soldering | Stations: CDB, CDEB, DIU, DDU, DMU Tools: T245, T245G, T245P, T245N |
| C245654 | Drag Cartridge 0.75 mm L 0.029 in |  | Drag soldering | Stations: CDB, CDEB, DIU, DDU, DMU Tools: T245, T245G, T245P, T245N |
| C245751 | Drag Cartridge 1.25 mm 0.049 in |  | Drag soldering | Stations: CDB, CDEB, DIU, DDU, DMU Tools: T245, T245G, T245P, T245N |
| C245651 | Drag Cartridge 1.25 mm L 0.049 in |  | Drag soldering | Stations: CDB, CDEB, DIU, DDU, DMU Tools: T245, T245G, T245P, T245N |
| C245667 | Drag Cartridge 1.25 mm S1 L 0.049 in |  | Drag soldering | Stations: CDB, CDEB, DIU, DDU, DMU Tools: T245, T245G, T245P, T245N |
| C245669 | Drag Cartridge 1.25 mm S2 L 0.049 in |  | Drag soldering | Stations: CDB, CDEB, DIU, DDU, DMU Tools: T245, T245G, T245P, T245N |
| C245796 | Drag Cartridge 2.2 x 0.75 mm 0.087 x 0.029 in |  | Drag soldering | Stations: CDB, CDEB, DIU, DDU, DMU Tools: T245, T245G, T245P, T245N |
| C245220 | Tunnel Cartridge 5.4 x 6 mm 0.213 x 0.236 in |  | Dual in Line IC | Stations: CDB, CDEB, DIU, DDU, DMU Tools: T245, T245G, T245P, T245N |

C245 Cartridge Range for T245 General Purpose Handles

| Ref. | Description | Image and dimensions | Suggested components | Compatible with |
|----------------|---|----------------------|----------------------|--|
| C245250 | Tunnel Cartridge 5.4 x 8 mm 0.213 x 0.315 in | | Dual in Line IC | Stations: CDB, CDEB, DIU, DDU, DMU Tools: T245, T245G, T245P, T245N |
| C245221 | Tunnel Cartridge 5.4 x 10 mm 0.213 x 0.394 in | | Dual in Line IC | Stations: CDB, CDEB, DIU, DDU, DMU Tools: T245, T245G, T245P, T245N |
| C245303 | Tunnel Cartridge 6.5 x 6 mm 0.256 x 0.236 in | | Dual in Line IC | Stations: CDB, CDEB, DIU, DDU, DMU Tools: T245, T245G, T245P, T245N |
| C245222 | Tunnel Cartridge 7.1 x 13 mm 0.279 x 0.512 in | | Dual in Line IC | Stations: CDB, CDEB, DIU, DDU, DMU Tools: T245, T245G, T245P, T245N |
| C245306 | Tunnel Cartridge 9.6 x 10 mm 0.378 x 0.394 in | | Dual in Line IC | Stations: CDB, CDEB, DIU, DDU, DMU Tools: T245, T245G, T245P, T245N |
| C245305 | Tunnel Cartridge 9.6 x 12 mm 0.378 x 0.472 in | | Dual in Line IC | Stations: CDB, CDEB, DIU, DDU, DMU Tools: T245, T245G, T245P, T245N |
| C245304 | Tunnel Cartridge 9.6 x 15 mm 0.378 x 0.591 in | | Dual in Line, IC | Stations: CD, CDE, DIU, DDU, DMU Tools: T245, T245G, T245P, T245N |
| C245215 | Tunnel Cartridge 9.6 x 18 mm 0.378 x 0.709 in | | Dual in Line IC | Stations: CDB, CDEB, DIU, DDU, DMU Tools: T245, T245G, T245P, T245N |

C245 Cartridge Range for T245 General Purpose Handles

| Ref. | Description | Image and dimensions | Suggested components | Compatible with |
|----------------|--|----------------------|----------------------|--|
| C245226 | Tunnel Cartridge 15.2 x 29 mm 0.598 x 1.142 in | | Dual in Line IC | Stations: CDB, CDEB, DIU, DDU, DMU Tools: T245, T245G, T245P, T245N |
| C245223 | QFP Cartridge 8.5 x 8.5 mm 0.335 x 0.335 in | | QFP | Stations: CDB, CDEB, DIU, DDU, DMU Tools: T245, T245G, T245P, T245N |
| C245224 | QFP Cartridge 12 x 12 mm 0.472 x 0.472 in | | QFP | Stations: CDB, CDEB, DIU, DDU, DMU Tools: T245, T245G, T245P, T245N |
| C245351 | QFP Cartridge 12.3 x 12.3 mm 0.484 x 0.484 in | | QFP | Stations: CDB, CDEB, DIU, DDU, DMU Tools: T245, T245G, T245P, T245N |
| C245228 | QFP Cartridge 12.4 x 15 mm 0.488 x 0.591 in | | QFP | Stations: CDB, CDEB, DIU, DDU, DMU Tools: T245, T245G, T245P, T245N |
| C245315 | QFP Cartridge 15 x 15 mm 0.591 x 0.591 in | | QFP | Stations: CDB, CDEB, DIU, DDU, DMU Tools: T245, T245G, T245P, T245N |
| C245352 | QFP Cartridge 15.4 x 15.4 mm 0.606 x 0.606 in | | QFP | Stations: CDB, CDEB, DIU, DDU, DMU Tools: T245, T245G, T245P, T245N |
| C245227 | QFP Cartridge 17.5 x 17.5 mm 0.689 x 0.689 in | | QFP | Stations: CDB, CDEB, DIU, DDU, DMU Tools: T245, T245G, T245P, T245N |

C245 Cartridge Range for T245 General Purpose Handles

| Ref. | Description | Image and dimensions | Suggested components | Compatible with |
|----------------|--|----------------------|--|--|
| C245344 | QFP Cartridge 26 x 26 mm 1.024 x 1.024 in | | QFP | Stations: CDB, CDEB, DIU, DDU, DMU Tools: T245, T245G, T245P, T245N |
| C245248 | Socket Cartridge 11.9 x 14.4 mm 0.469 x 0.571 in | | PLCC sockets | Stations: CDB, CDEB, DIU, DDU, DMU Tools: T245, T245G, T245P, T245N |
| C245247 | Socket Cartridge 17 x 17 mm 0.669 x 0.669 in | | PLCC sockets | Stations: CDB, CDEB, DIU, DDU, DMU Tools: T245, T245G, T245P, T245N |
| C245053 | Heat Staking Cartridge Ø 3.8 mm Ø 0.149 in | | Chrome finish, design for plastic rivets | Stations: CDB, CDEB, DIU, DDU, DMU Tools: T245, T245G, T245P, T245N |
| C245052 | Heat Staking Cartridge Ø 4.9 mm Ø 0.193 in | | Chrome finish, design for plastic rivets | Stations: CDB, CDEB, DIU, DDU, DMU Tools: T245, T245G, T245P, T245N |
| C245054 | Heat Staking Cartridge Ø 6.5 mm Ø 0.256 in | | Chrome finish, design for plastic rivets | Stations: CDB, CDEB, DIU, DDU, DMU Tools: T245, T245G, T245P, T245N |
| C245798 | Heat Staking Cartridge Ø 8 mm Ø 0.315 in | | Chrome finish, design for plastic rivets | Stations: CDB, CDEB, DIU, DDU, DMU Tools: T245, T245G, T245P, T245N |
| C245791 | Heat Staking Cartridge Ø 9.8 mm Ø 0.386 in | | Chrome finish, design for plastic rivets | Stations: CDB, CDEB, DIU, DDU, DMU Tools: T245, T245G, T245P, T245N |

C245 Cartridge Range for T245 General Purpose Handles

| Ref. | Description | Image and dimensions | Suggested components | Compatible with |
|----------------|--|----------------------|--|--|
| C245143 | Double Heat Staking Cartridge Ø 1.8 mm Ø 0.071 in | | Chrome finish, design for plastic rivets | Stations: CDB, CDEB, DIU, DDU, DMU Tools: T245, T245G, T245P, T245N |
| C245163 | Hollow Heat Staking Cartridge Ø 2.5 mm Ø 0.098 in | | Chrome finish, design for plastic rivets | Stations: CDB, CDEB, DIU, DDU, DMU Tools: T245, T245G, T245P, T245N |
| C245166 | Plastics Inox. Cartridge Ø 1.7 mm Ø 0.067 in | | Plastics | Stations: CDB, CDEB, DIU, DDU, DMU Tools: T245, T245G, T245P, T245N |
| C245167 | Thermal Hole-Punch Cartridge for Plastic Ø 2.1 mm Ø 0.083 in | | Plastics | Stations: CDB, CDEB, DIU, DDU, DMU Tools: T245, T245G, T245P, T245N |
| C245168 | Thermal Hole-Punch Cartridge for Plastic Ø 3.1 mm Ø 0.122 in | | Plastics | Stations: CDB, CDEB, DIU, DDU, DMU Tools: T245, T245G, T245P, T245N |
| C245688 | Heat Staking Bend Cartridge Ø 3.2 mm Ø 0.125 in | | Plastics | Stations: CDB, CDEB, DIU, DDU, DMU Tools: T245, T245G, T245P, T245N |
| C245312 | Heat Staking Cartridge Ø 3.2 mm Ø 0.126 in | | Plastics | Stations: CDB, CDEB, DIU, DDU, DMU Tools: T245, T245G, T245P, T245N |
| C245313 | Cartridge for Plastics Ø 4.1 mm Ø 0.161 in | | Plastics | Stations: CDB, CDEB, DIU, DDU, DMU Tools: T245, T245G, T245P, T245N |
| C245123 | Cartridge for Plastics 4 x 4 mm 0.157 in | | Plastics | Stations: CDB, CDEB, DIU, DDU, DMU Tools: T245, T245G, T245P, T245N |

C245 Cartridge Range for T245 General Purpose Handles

| | Ref. | Description | Image and dimensions | Suggested components | Compatible with |
|--|----------------|--|----------------------|---------------------------------------|--|
| | C245124 | Cartridge for Plastics 4.25 x 2 mm 0.167 x 0.079 in | | Plastics | Stations: CDB, CDEB, DIU, DDU, DMU Tools: T245, T245G, T245P, T245N |
| | C245311 | Cartridge for Plastics 20 x 6 mm 0.787 x 0.256 in | | Plastics | Stations: CDB, CDEB, DIU, DDU, DMU Tools: T245, T245G, T245P, T245N |
| | C245109 | Conformal Coating Removal Cartridge 4.3 x 0.1 mm 0.169 x 0.004 in | | Remove underfill encapsulants | Stations: CDB, CDEB, DIU, DDU, DMU Tools: T245, T245G, T245P, T245N |
| | C245138 | Cutter Cartridge 12 mm 0.472 in | | Plastic Rubber cutter | Stations: CDB, CDEB, DIU, DDU, DMU Tools: T245, T245G, T245P, T245N |
| | C245121 | Cutter Cartridge 13 mm 0.512 in | | Plastic Rubber cutter | Stations: CDB, CDEB, DIU, DDU, DMU Tools: T245, T245G, T245P, T245N |
| | C245119 | Conical Teflon Cartridge Ø 1 mm Ø 0.039 in | | Plastics | Stations: CDB, CDEB, DIU, DDU, DMU Tools: T245, T245G, T245P, T245N |
| | C245116 | Pin/Connector Cartridge R. 1 mm R. 0.039 in | | Through-hole Coaxial connector | Stations: CDB, CDEB, DIU, DDU, DMU Tools: T245, T245G, T245P, T245N |
| | C245122 | Pin/Connector Cartridge 1.5 x 0.5 mm 0.059 x 0.019 in | | Cylinder parts | Stations: CDB, CDEB, DIU, DDU, DMU Tools: T245, T245G, T245P, T245N |
| | C245764 | Fine Pitch Cartridge Ø 0.5 mm Ø 0.019 in | | Package 0603 QFP, IC Fine pitch | Stations: CDB, CDEB, DIU, DDU, DMU Tools: T245, T245G, T245P, T245N |

C245 Cartridge Range for T245 General Purpose Handles

| | Ref. | Description | Image and dimensions | Suggested components | Compatible with |
|--|-----------------|---|----------------------|--|--|
| | C245771 | Bent Cartridge 1 x 0.1 mm 0.039 x 0.004 in | | Cable soldering to connector Fine pitch | Stations: CDB, CDEB, DIU, DDU, DMU Tools: T245, T245G, T245P, T245N |
| | C245117 | Flat Cartridge Ø 1.4 mm Ø 0.055 in | | Through-hole | Stations: CDB, CDEB, DIU, DDU, DMU Tools: T245, T245G, T245P, T245N |
| | C245118 | Pin/Wire Cartridge 0.4 mm 0.016 in | | Through-hole Wire tinning | Stations: CDB, CDEB, DIU, DDU, DMU Tools: T245, T245G, T245P, T245N |
| | C245268 | Pin/Wire Cartridge 1.5 mm 0.059 in | | Through-hole | Stations: CDB, CDEB, DIU, DDU, DMU Tools: T245, T245G, T245P, T245N |
| | C245136 | Micro Stick Switch Cartridge 7.1 x 6.5 mm 0.279 x 0.256 in | | Micro Stick desoldering | Stations: CDB, CDEB, DIU, DDU, DMU Tools: T245, T245G, T245P, T245N |
| | C245772 | Nickel Cartridge Ø 1.4 x 0.7 mm S1 Ø 0.055 x 0.028 in | | HMP Soldering | Stations: CDB, CDEB, DIU, DDU, DMU Tools: T245, T245G, T245P, T245N |
| | C245009 | S-Lead Cartridge 4.5 x 1.8 mm 0.177 x 0.071 in | | Drag Soldering | Stations: CDB, CDEB, DIU, DDU, DMU Tools: T245, T245G, T245P, T245N |
| | C245010 | J-Lead Cartridge 4.4 x 1.8 mm 0.177 x 0.071 in | | Drag Soldering J-lead | Stations: CDB, CDEB, DIU, DDU, DMU Tools: T245, T245G, T245P, T245N |
| | C245SP01 | Solder Pot Cartridge 15 x 18 mm 0.591 x 0.709 in | | Tinning wires, Desoldering and Through-hole Multipin components | Stations: CDB, CDEB, DIU, DDU, DMU Tools: T245, T245G, T245P, T245N |

C245E Extended Tip Life Cartridge Range for T245 General Purpose Handles



| Ref. | Description | Image and dimensions | Suggested components | Compatible with |
|-----------------|--|----------------------|----------------------|--|
| C245159E | Chisel Cartridge 0.8 x 0.4 mm 0.031 x 0.016 in | | General use | Stations: CDB, CDEB, DIU, DDU, DMU Tools: T245, T245G, T245P, T245N |
| C245158E | Chisel Cartridge 1.2 x 0.4 mm 0.047 x 0.016 in | | General use | Stations: CDB, CDEB, DIU, DDU, DMU Tools: T245, T245G, T245P, T245N |
| C245160E | Chisel Cartridge 1.6 x 0.5 mm 0.063 x 0.020 in | | General use | Stations: CDB, CDEB, DIU, DDU, DMU Tools: T245, T245G, T245P, T245N |
| C245155E | Chisel Cartridge 2.4 x 0.8 mm 0.094 x 0.031 in | | General use | Stations: CDB, CDEB, DIU, DDU, DMU Tools: T245, T245G, T245P, T245N |
| C245735E | Chisel Cartridge 2.7 x 1 mm 0.106 x 0.039 in | | General use | Stations: CDB, CDEB, DIU, DDU, DMU Tools: T245, T245G, T245P, T245N |
| C245161E | Chisel Cartridge 3.2 x 0.8 mm 0.126 x 0.031 in | | General use | Stations: CDB, CDEB, DIU, DDU, DMU Tools: T245, T245G, T245P, T245N |
| C245070E | Chisel Cartridge 5 x 1.7 mm 0.197 x 0.067 in | | General use | Stations: CDB, CDEB, DIU, DDU, DMU Tools: T245, T245G, T245P, T245N |

C245E Extended Tip Life Cartridge Range for T245 General Purpose Handles

| Ref. | Description | Image and dimensions | Suggested components | Compatible with |
|-----------------|--|----------------------|--------------------------------|--|
| C245968E | Chisel Cartridge 6.6 x 1.8 mm 0.260 x 0.071 in | | General use | Stations: CDB, CDEB, DIU, DDU, DMU Tools: T245, T245G, T245P, T245N |
| C245156E | Bevel Cartridge Ø 2.4 mm Ø 0.094 in | | Drag soldering Through-hole | Stations: CDB, CDEB, DIU, DDU, DMU Tools: T245, T245G, T245P, T245N |
| C245354E | Bevel Cartridge Ø 3.5 mm L Ø 0.138 in | | Drag soldering Through-hole | Stations: CDB, CDEB, DIU, DDU, DMU Tools: T245, T245G, T245P, T245N |
| C245157E | Knife Cartridge 7.2 mm 0.283 in | | Drag soldering Through-hole | Stations: CDB, CDEB, DIU, DDU, DMU Tools: T245, T245G, T245P, T245N |

C250 Cartridge Range

for AL250 Auto-Feed Iron and AP250 Solder Feed Iron



| | Ref. | Description | Image and dimensions | Suggested components | Compatible with |
|--|----------------|---|----------------------|---|--|
| | C250420 | Conical Bent Cartridge Ø 0.4 mm Ø 0.016 in | | Package 0201, 0402 Fine pitch 0.65 mm QFP, IC | Stations: AL, CDA Tools: AL250, AP250 |
| | C250401 | Conical Bent Cartridge Ø 0.6 mm Ø 0.023 in | | Package 0603 QFP, IC | Stations: AL, CDA Tools: AL250, AP250 |
| | C250402 | Conical Bent Cartridge Ø 0.8 mm Ø 0.031 in | | General use | Stations: AL, CDA Tools: AL250, AP250 |
| | C250403 | Conical Bent Cartridge Ø 1 mm Ø 0.039 in | | General use | Stations: AL, CDA Tools: AL250, AP250 |
| | C250409 | Conical Bent Cartridge Ø 1.7 mm Ø 0.067 in | | General use | Stations: AL, CDA Tools: AL250, AP250 |
| | C250410 | Conical Bent Cartridge Ø 2.2 mm Ø 0.087 in | | General use | Stations: AL, CDA Tools: AL250, AP250 |
| | C250404 | Chisel Bent Cartridge 1.2 x 0.7 mm 0.047 x 0.028 in | | General use | Stations: AL, CDA Tools: AL250, AP250 |

C250 Cartridge Range for AL250 Auto-Feed Iron and AP250 Solder Feed Iron

| | Ref. | Description | Image and dimensions | Suggested components | Compatible with |
|--|----------------|---|----------------------|----------------------|--|
| | C250405 | Chisel Bent Cartridge 1.8 x 0.8 mm 0.071 x 0.032 in | | General use | Stations: AL, CDA Tools: AL250, AP250 |
| | C250406 | Chisel Bent Cartridge 2.2 x 1 mm 0.087 x 0.039 in | | General use | Stations: AL, CDA Tools: AL250, AP250 |
| | C250418 | Chisel Bent Cartridge 3.2 x 1.5 mm 0.126 x 0.059 in | | General use | Stations: AL, CDA Tools: AL250, AP250 |
| | C250412 | Chisel Bent Cartridge 4.8 x 1.5 mm 0.189 x 0.059 in | | General use | Stations: AL, CDA Tools: AL250, AP250 |
| | C250407 | Chisel Cartridge 1.2 x 0.7 mm 0.047 x 0.028 in | | General use | Stations: AL, CDA Tools: AL250, AP250 |
| | C250408 | Chisel Cartridge 2.2 x 1 mm S1 0.087 x 0.039 in | | General use | Stations: AL, CDA Tools: AL250, AP250 |
| | C250413 | Chisel Cartridge 2.2 x 1 mm S2 0.087 x 0.039 in | | General use | Stations: AL, CDA Tools: AL250, AP250 |
| | C250411 | Chisel Cartridge 4.8 x 1.5 mm 0.189 x 0.059 in | | General use | Stations: AL, CDA Tools: AL250, AP250 |

C250 Cartridge Range for **AL250** Auto-Feed Iron and **AP250** Solder Feed Iron

| Ref. | Description | Image and dimensions | Suggested components | Compatible with |
|----------------|---|----------------------|--------------------------------|--|
| C250426 | Bevel Cartridge Ø 1.3 mm Ø 0.051 in | | Drag soldering Through-hole | Stations: AL, CDA Tools: AL250, AP250 |
| C250414 | Bevel Cartridge Ø 2.2 mm Ø 0.087 in | | Drag soldering Through-hole | Stations: AL, CDA Tools: AL250, AP250 |
| C250424 | Bevel Cartridge Ø 3 mm Ø 0.118 in | | Drag soldering Through-hole | Stations: AL, CDA Tools: AL250, AP250 |
| C250415 | Bevel Cartridge Ø 3.8 mm Ø 0.149 in | | Drag soldering Through-hole | Stations: AL, CDA Tools: AL250, AP250 |

C420 Cartridge Range
for **AT420** and **HT420** Thermal Tweezers



| Ref. | Description | Image and dimensions | Suggested components | Compatible with |
|----------------|--------------------------------------|----------------------|--------------------------------------|--|
| C420271 | Chip Cartridge 1.5 mm 0.059 in | | SMD resistors SMD capacitors | Stations: DIU, DDU, DMU Tools: AT420, HT420 |
| C420287 | Chip Cartridge 2 mm 0.079 in | | Customized | Stations: DIU, DDU, DMU Tools: AT420, HT420 |
| C420272 | Chip Cartridge 2.6 mm 0.102 in | | SMD resistors SMD capacitors | Stations: DIU, DDU, DMU Tools: AT420, HT420 |
| C420279 | QFP Cartridge 8 mm 0.315 in | | QFP PLCC | Stations: DIU, DDU, DMU Tools: AT420, HT420 |
| C420280 | QFP Cartridge 11 mm 0.433 in | | QFP PLCC | Stations: DIU, DDU, DMU Tools: AT420, HT420 |
| C420288 | QFP Cartridge 14.5 mm 0.571 in | | QFP PLCC | Stations: DIU, DDU, DMU Tools: AT420, HT420 |
| C420273 | Blade Cartridge 4 mm 0.157 in | | Package 1210, 1812 SO, SOT DIP | Stations: DIU, DDU, DMU Tools: AT420, HT420 |

C420 Cartridge Range for AT420 and HT420 Thermal Tweezers

| | Ref. | Description | Image and dimensions | Suggested components | Compatible with |
|--|----------------|--|----------------------|---------------------------------------|--|
| | C420274 | Blade Cartridge 6 mm 0.236 in | | DIP IC | Stations: DIU, DDU, DMU Tools: AT420, HT420 |
| | C420275 | Blade Cartridge 8 mm 0.315 in | | DIP IC | Stations: DIU, DDU, DMU Tools: AT420, HT420 |
| | C420276 | Blade Cartridge 10 mm 0.394 in | | DIP IC | Stations: DIU, DDU, DMU Tools: AT420, HT420 |
| | C420277 | Blade Cartridge 15 mm 0.591 in | | DIP IC | Stations: DIU, DDU, DMU Tools: AT420, HT420 |
| | C420278 | Blade Cartridge 20 mm 0.787 in | | DIP IC | Stations: DIU, DDU, DMU Tools: AT420, HT420 |
| | C420285 | Blade Cartridge 22 mm 0.866 in | | DIP IC | Stations: DIU, DDU, DMU Tools: AT420, HT420 |
| | C420283 | Blade Cartridge 50 mm 1.968 in | | Pad cleaning Connector desoldering | Stations: DIU, DDU, DMU Tools: AT420, HT420 |
| | C420286 | "U" Shape Cartridge 15.6 x 14.3 mm 0.614 x 0.563 in | | Customized | Stations: DIU, DDU, DMU Tools: AT420, HT420 |





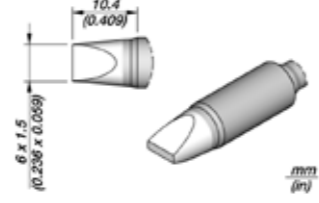
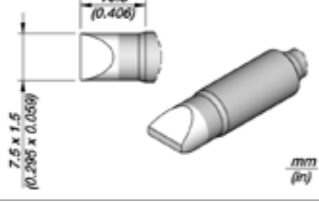
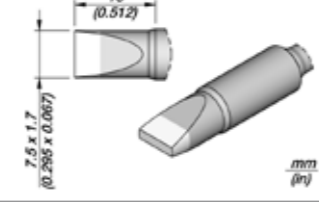
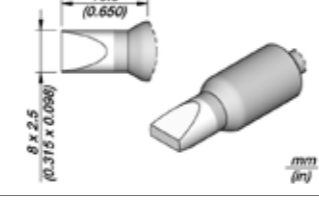

C470 Cartridge Range for T470 HD Handles and HT470 HD Thermal Tweezers

| | Ref. | Description | Image and dimensions | Suggested components | Compatible with |
|--|----------------|---|----------------------|----------------------|---|
| | C470001 | Conical Cartridge Ø 1.7 mm Ø 0.067 in | | General use | Station: HDU Tools: T470, T470S, T470F, T470M, T470Z, T470N |
| | C470008 | Conical Bent Cartridge Ø 3.5 mm Ø 0.138 in | | General use | Station: HDU Tools: T470, T470S, T470F, T470M, T470Z, T470N |
| | C470013 | Chisel Cartridge 2 x 0.9 mm 0.079 x 0.035 in | | General use | Station: HDU Tools: T470, T470S, T470F, T470M, T470Z, T470N |
| | C470036 | Chisel Cartridge 2 x 1 mm 0.079 x 0.039 in | | General use | Station: HDU Tools: T470, T470S, T470F, T470M, T470Z, T470N |
| | C470014 | Chisel Cartridge 4 x 1.3 mm S1 0.157 x 0.051 in | | General use | Station: HDU Tools: T470, T470S, T470F, T470M, T470Z, T470N |
| | C470040 | Chisel Cartridge 4 x 1.3 mm S2 0.157 x 0.051 in | | General use | Station: HDU Tools: T470, T470S, T470F, T470M, T470Z, T470N |
| | C470035 | Chisel Cartridge 4 x 2.5 mm 0.157 x 0.098 in | | General use | Station: HDU Tools: T470, T470S, T470F, T470M, T470Z, T470N |



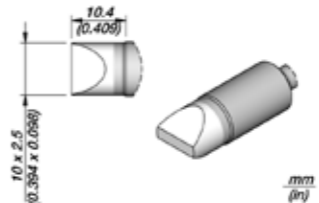
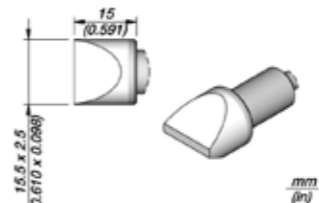
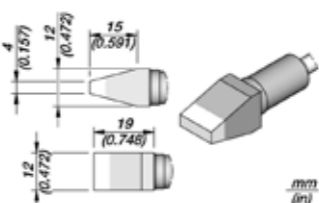
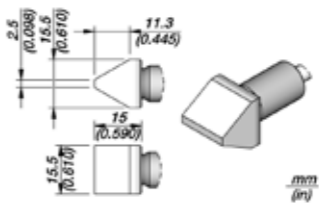
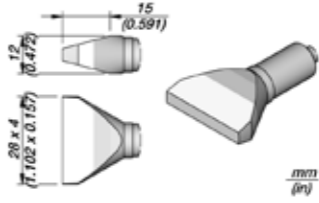

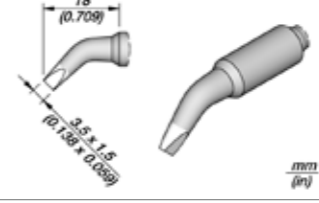
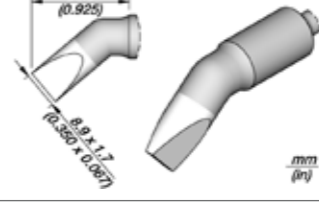
C470 Cartridge Range for T470 HD Handles and HT470 HD Thermal Tweezers

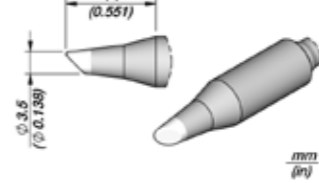
| | Ref. | Description | Image and dimensions | Suggested components | Compatible with |
|---|----------------|--|---|----------------------------|---|
|  | C470017 | Chisel Cartridge 5 x 1.2 mm 0.197 x 0.047 in |  | General use | Station: HDU Tools: T470, T470S, T470F, T470M, T470Z, T470N |
| | C470009 | Chisel Cartridge 5.5 x 1.5 mm 0.216 x 0.059 in |  | General use Sheet metal | Station: HDU Tools: T470, T470S, T470F, T470M, T470Z, T470N |
| | C470002 | Chisel Cartridge 6 x 1.5 mm 0.236 x 0.059 in |  | General use Sheet metal | Station: HDU Tools: T470, T470S, T470F, T470M, T470Z, T470N |
| | C470015 | Chisel Cartridge 6 x 1.7 mm 0.236 x 0.067 in |  | General use | Station: HDU Tools: T470, T470S, T470F, T470M, T470Z, T470N |
| | C470004 | Chisel Cartridge 7.5 x 1.5 mm 0.295 x 0.059 in |  | General use Sheet metal | Station: HDU Tools: T470, T470S, T470F, T470M, T470Z, T470N |
| | C470016 | Chisel Cartridge 7.5 x 1.7 mm 0.295 x 0.067 in |  | General use | Station: HDU Tools: T470, T470S, T470F, T470M, T470Z, T470N |
| | C470058 | Chisel Cartridge 8 x 2.5 mm 0.315 x 0.098 in |  | General use Sheet metal | Station: HDU Tools: T470, T470S, T470F, T470M, T470Z, T470N |
| | C470039 | Chisel Cartridge 8.5 x 2.5 mm 0.335 x 0.098 in |  | General use Sheet metal | Station: HDU Tools: T470, T470S, T470F, T470M, T470Z, T470N |

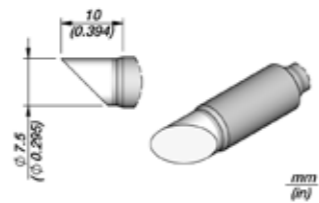
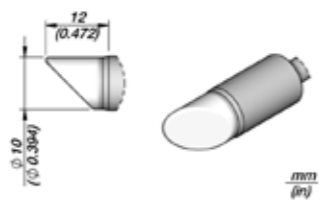

C470 Cartridge Range for T470 HD Handles and HT470 HD Thermal Tweezers

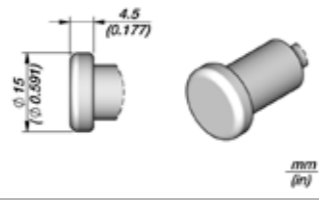
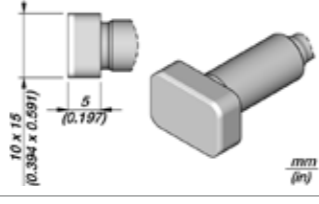
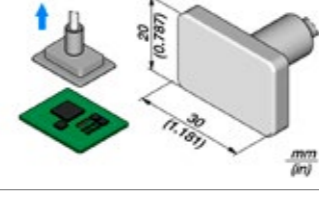
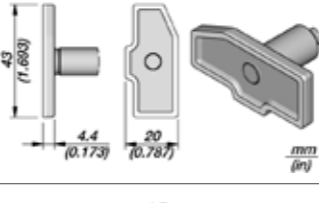
| | Ref. | Description | Image and dimensions | Suggested components | Compatible with |
|---|----------------|---|---|----------------------------|---|
|  | C470006 | Chisel Cartridge 10 x 2.5 mm 0.394 x 0.098 in |  | General use Sheet metal | Station: HDU Tools: T470, T470S, T470F, T470M, T470Z, T470N |
| | C470007 | Chisel Cartridge 15.5 x 2.5 mm 0.610 x 0.098 in |  | General use Sheet metal | Station: HDU Tools: T470, T470S, T470F, T470M, T470Z, T470N |
| | C470021 | Chisel Cartridge 12 x 4 mm 0.472 x 0.157 in |  | General use Sheet metal | Station: HDU Tools: T470, T470S, T470F, T470M, T470Z, T470N |
| | C470067 | Chisel Cartridge 15.5 X 2.5 mm 0.610 x 0.098 in |  | General use Sheet metal | Station: HDU Tools: T470, T470S, T470F, T470M, T470Z, T470N, HT470 |
| | C470022 | Chisel Cartridge 28 x 4 mm 1.102 x 0.157 in |  | Sheet metal | Station: HDU Tools: T470, T470S, T470F, T470M, T470Z, T470N |
|  | C470034 | Chisel Bent Cartridge 3.5 x 1.5 mm 0.138 x 0.059 in |  | General use | Station: HDU Tools: T470, T470S, T470F, T470M, T470Z, T470N |
| | C470018 | Chisel Bent Cartridge 8.9 x 1.7 mm 0.350 x 0.067 in |  | General use Sheet metal | Station: HDU Tools: T470, T470S, T470F, T470M, T470Z, T470N |
|  | C470019 | Bevel Cartridge Ø 3.5 mm Ø 0.138 in |  | General use | Station: HDU Tools: T470, T470S, T470F, T470M, T470Z, T470N |

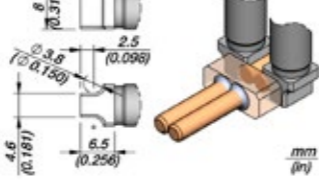
C470 Cartridges for **T470** HD Handles and **HT470** HD Thermal Tweezers

| | Ref. | Description | Image and dimensions | Suggested components | Compatible with |
|---|----------------|--|---|--|--|
|  | C470003 | Bevel Cartridge Ø 7.5 mm Ø 0.295 in |  | General use Sheet metal | Station: HDU Tools: T470, T470S, T470F, T470M, T470Z, T470N |
| | C470056 | Bevel Cartridge Ø 10 mm Ø 0.394 in |  | Wide area Shield desoldering Sheet metal | Station: HDU Tools: T470, T470S, T470F, T470M, T470Z, T470N |
|  | C470005 | Flat Cartridge Ø 15 mm Ø 0.591 in |  | Shield desoldering Metal PCB Sheet metal | Station: HDU Tools: T470, T470S, T470F, T470M, T470Z, T470N |
| | C470044 | Flat Cartridge 10 x 15 mm 0.394 x 0.591 in |  | Shield desoldering Metal PCB Sheet metal | Station: HDU Tools: T470, T470S, T470F, T470M, T470Z, T470N |
| | C470057 | Flat Cartridge 20 x 30 mm 0.787 x 1.181 in |  | Shield desoldering Metal PCB Sheet metal | Station: HDU Tools: T470, T470S, T470F, T470M, T470Z, T470N |
| | C470027 | Shield Cartridge 43 x 20 mm 1.693 x 0.787 in |  | Shield desoldering | Station: HDU Tools: T470, T470S, T470F, T470M, T470Z, T470N |
| | C470031 | Pin/Connector Cartridge Ø 3.3 mm Ø 0.126 in |  | Cable Through-hole | Station: HDU Tools: T470, T470S, T470F, T470M, T470Z, T470N |
| | C470050 | Pin/Connector Cartridge Ø 3.8 mm Ø 0.150 in |  | Cable Connectors | Station: HDU Tools: T470, T470S, T470F, T470M, T470Z, T470N, HT470 |

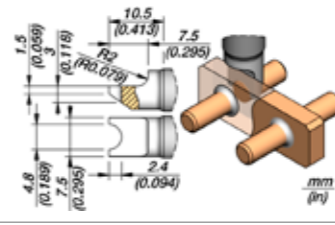
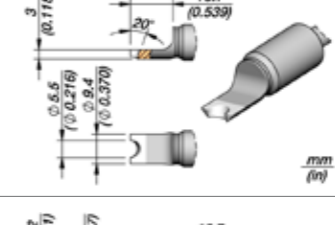
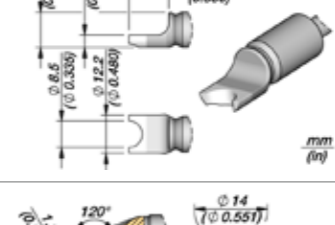
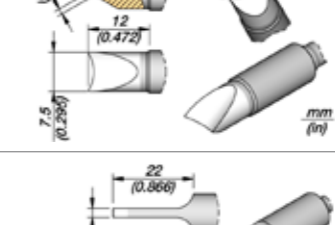
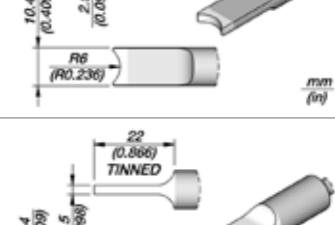
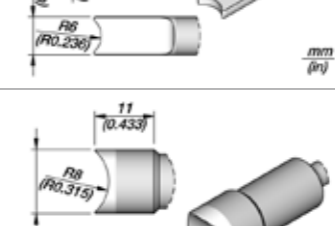
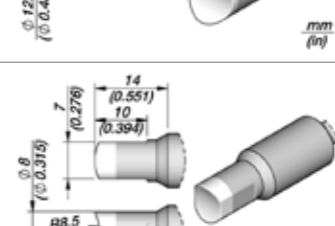
C470 Cartridges for **T470** HD Handles and **HT470** HD Thermal Tweezers

| | Ref. | Description | Image and dimensions | Suggested components | Compatible with |
|---|----------------|---|---|-----------------------------------|---|
|  | C470042 | Pin/Connector Cartridge Ø 4.8 mm Ø 0.189 in |  | Cable Through-hole | Station: HDU Tools: T470, T470S, T470F, T470M, T470Z, T470N, HT470 |
| | C470066 | Pin/Connector Cartridge Ø 5.5 mm Ø 0.216 in |  | Cable Through-hole | Station: HDU Tools: T470, T470S, T470F, T470M, T470Z, T470N |
| | C470065 | Pin/Connector Cartridge Ø 8.5 mm Ø 0.335 in |  | Cable Through-hole | Station: HDU Tools: T470, T470S, T470F, T470M, T470Z, T470N |
| | C470047 | Pin/Connector Cartridge Ø 14 mm Ø 0.551 in |  | Cable Through-hole | Station: HDU Tools: T470, T470S, T470F, T470M, T470Z, T470N |
| | C470012 | Pin/Connector Cartridge R. 6 mm S1 R. 0.236 in |  | Cables Connectors | Station: HDU Tools: T470, T470S, T470F, T470M, T470Z, T470N |
| | C470038 | Pin/Connector Cartridge R. 6 mm S2 R. 0.236 in |  | Wide area Cables Connectors | Station: HDU Tools: T470, T470S, T470F, T470M, T470Z, T470N |
| | C470010 | Pin/Connector Cartridge R. 8 mm R. 0.315 in |  | Cables connectors | Station: HDU Tools: T470, T470S, T470F, T470M, T470Z, T470N |
| | C470052 | Pin/Connector Cartridge R. 8.5 mm R. 0.335 in |  | Cables connectors | Station: HDU Tools: T470, T470S, T470F, T470M, T470Z, T470N |

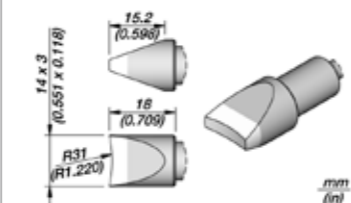
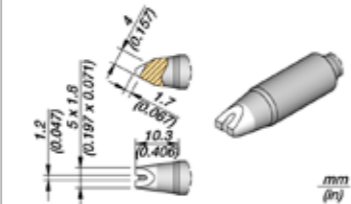
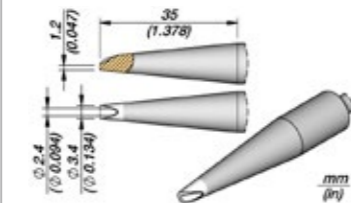
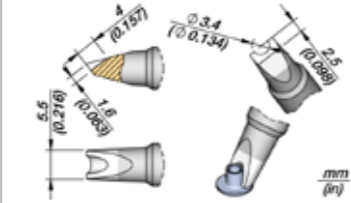
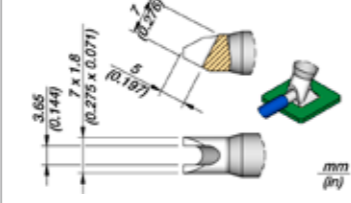
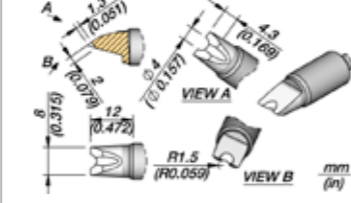
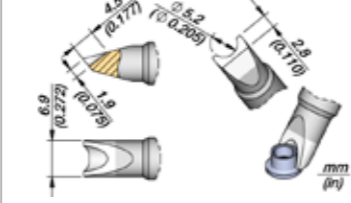
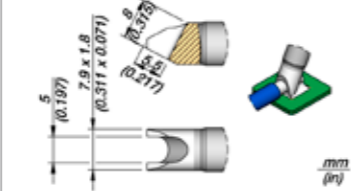

C470 Cartridge Range for T470 HD Handles and HT470 HD Thermal Tweezers

| Ref. | Description | Image and dimensions | Suggested components | Compatible with |
|----------------|--|---|----------------------|---|
| C470029 | Pin/Connector Cartridge R. 31 mm R. 1.220 in |  | Connectors | Station: HDU Tools: T470, T470S, T470F, T470M, T470Z, T470N |
| C470028 | Pin/Connector Cartridge Ø 1.2 mm Ø 0.047 in |  | Cable Through-hole | Station: HDU Tools: T470, T470S, T470F, T470M, T470Z, T470N |
| C470020 | Pin Cartridge Ø 2.4 mm Ø 0.094 in |  | Through-hole | Station: HDU Tools: T470, T470S, T470F, T470M, T470Z, T470N |
| C470048 | Pin/Connector Cartridge Ø 3.4 mm Ø 0.134 in |  | Cable Through-hole | Station: HDU Tools: T470, T470S, T470F, T470M, T470Z, T470N |
| C470033 | Pin/Connector Cartridge Ø 3.65 mm Ø 0.144 in |  | Cable Through-hole | Station: HDU Tools: T470, T470S, T470F, T470M, T470Z, T470N |
| C470055 | Pin/Connector Cartridge Ø 4 mm Ø 0.157 in |  | Cable Through-hole | Station: HDU Tools: T470, T470S, T470F, T470M, T470Z, T470N |
| C470049 | Pin/Connector Cartridge Ø 5.2 mm Ø 0.205 in |  | Cable Through-hole | Station: HDU Tools: T470, T470S, T470F, T470M, T470Z, T470N |
| C470030 | Pin/Connector Cartridge Ø 5 mm Ø 0.197 in |  | Cable Through-hole | Station: HDU Tools: T470, T470S, T470F, T470M, T470Z, T470N |

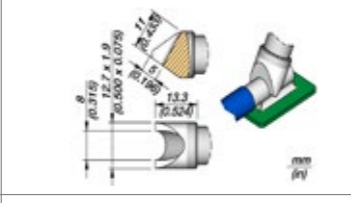
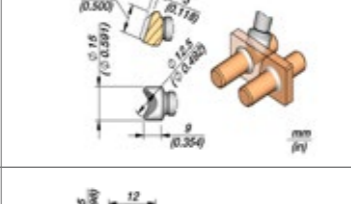
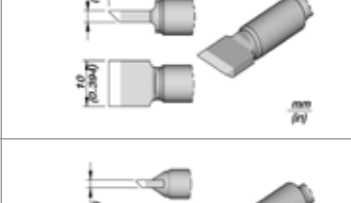
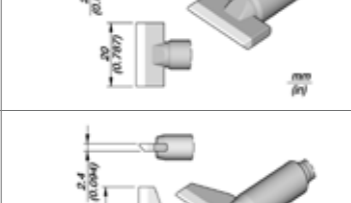
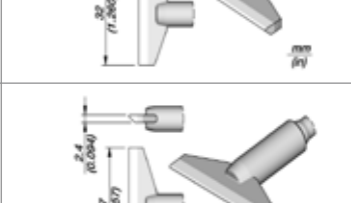
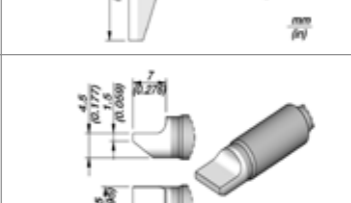
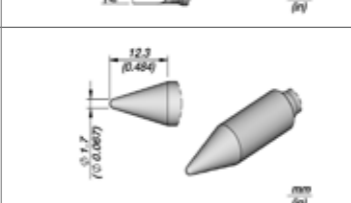
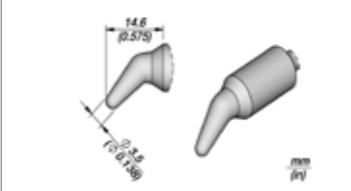
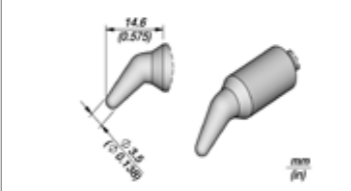
C470 Cartridge Range for T470 HD Handles and HT470 HD Thermal Tweezers

| Ref. | Description | Image and dimensions | Suggested components | Compatible with |
|----------------|--|---|---------------------------------------|---|
| C470037 | Pin/Connector Cartridge Ø 8 mm Ø 0.315 in |  | Cable Through-hole | Station: HDU Tools: T470, T470S, T470F, T470M, T470Z, T470N |
| C470041 | Pin/Connector Cartridge Ø 12.5 mm Ø 0.492 in |  | Cable Through-hole | Station: HDU Tools: T470, T470S, T470F, T470M, T470Z, T470N |
| C470064 | Blade Cartridge 10 mm 0.394 in |  | Pad cleaning Connector desoldering | Station: HDU Tools: T470, T470S, T470F, T470M, T470Z, T470N, HT470 |
| C470059 | Blade Cartridge 20 mm 0.787 in |  | Pad cleaning Connector desoldering | Station: HDU Tools: T470, T470S, T470F, T470M, T470Z, T470N, HT470 |
| C470023 | Blade Cartridge 32 mm 1.260 in |  | Pad cleaning Connector desoldering | Station: HDU Tools: T470, T470S, T470F, T470M, T470Z, T470N, HT470 |
| C470063 | Blade Cartridge 37 mm 1.457 in |  | Pad cleaning Connector desoldering | Station: HDU Tools: T470, T470S, T470F, T470M, T470Z, T470N, HT470 |
| C470046 | Single Flat Cartridge 7.5 mm 0.295 in |  | General use Sheet metal | Station: HDU Tools: T470, T470S, T470F, T470M, T470Z, T470N, HT470 |
| C470025 | Cartridge for Plastics Ø 1.7 mm Ø 0.067 in |  | Plastics | Station: HDU Tools: T470, T470S, T470F, T470M, T470Z, T470N |
| C470026 | Cartridge for Plastics Ø 3.5 mm Ø 0.138 in |  | Plastics | Station: HDU Tools: T470, T470S, T470F, T470M, T470Z, T470N |

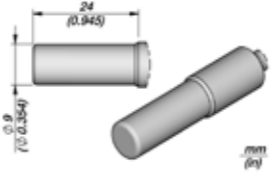
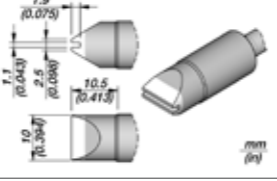
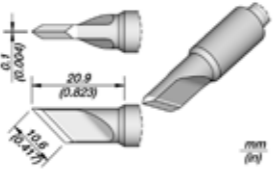
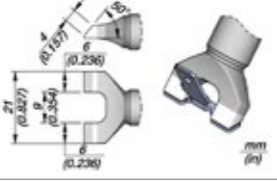
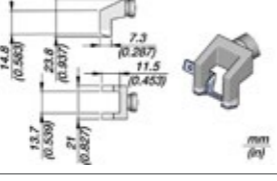
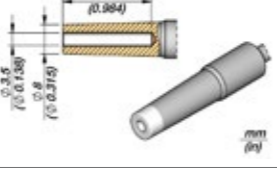
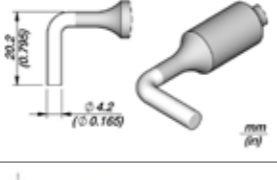
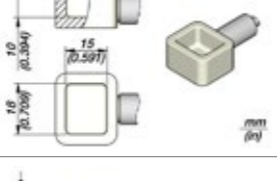
C470 Cartridge Range for T470 HD Handles and HT470 HD Thermal Tweezers

| Ref. | Description | Image and dimensions | Suggested components | Compatible with |
|-----------------|--|---|---|---|
| C470032 | Cartridge for Plastics Ø 9 mm Ø 0.354 in |  | Plastics | Station: HDU Tools: T470, T470S, T470F, T470M, T470Z, T470N |
| C470043 | Groove Cartridge 1.1 x 10 mm 0.043 x 0.394 in |  | Wire soldering | Station: HDU Tools: T470, T470S, T470F, T470M, T470Z, T470N |
| C470061 | Knife Cartridge 10.6 mm 0.417 in |  | Drag Soldering | Station: HDU Tools: T470, T470S, T470F, T470M, T470Z, T470N |
| C470051 | Blade Split Cartridge 21 mm 0.827 in |  | Connectors | Station: HDU Tools: T470, T470S, T470F, T470M, T470Z, T470N |
| C470070 | Faston Terminal Cartridge 21 mm 0.827 in |  | Connectors | Station: HDU Tools: T470, T470S, T470F, T470M, T470Z, T470N |
| C470045 | Pin Cartridge Ø 3.5 mm Ø 0.138 in |  | Through-hole Male connector | Station: HDU Tools: T470, T470S, T470F, T470M, T470Z, T470N |
| C470011 | Hook Cartridge Ø 4.2 mm Ø 0.165 in |  | Difficult to reach | Station: HDU Tools: T470, T470S, T470F, T470M, T470Z, T470N |
| C470SP01 | Solder Pot Cartridge 15 x 18 mm 0.591 x 0.709 in |  | Tinnig wires Desoldering Through-hole Multipin components | Station: HDU Tools: T470, T470S, T470F, T470M, T470Z, T470N |
| C470SP42 | Solder Pot Cartridge 40 x 40 mm 1.575 x 1.575 in |  | Tinnig wires Desoldering Through-hole Multipin components | Station: HDU Tools: T470, T470S, T470F, T470M, T470Z, T470N |

C360 Tip Range
for DS360 Micro Desoldering Iron



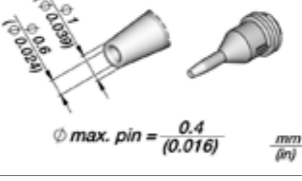
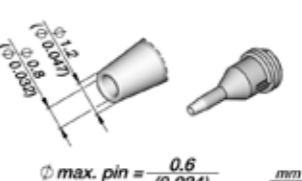
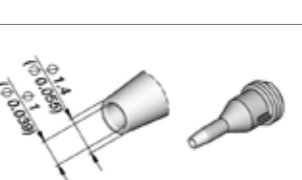
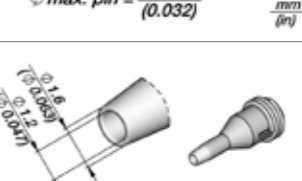
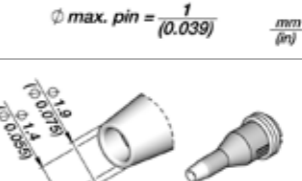
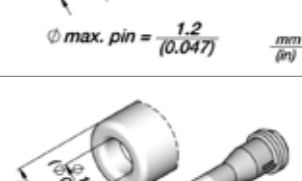
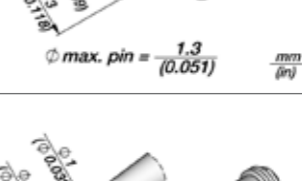

| Ref. | Description | Image and dimensions | Suggested components | Compatible with |
|----------------|---|---|--------------------------|--|
| C360001 | Micro Desoldering Tip Ø 0.6 mm Ø 0.024 in |  | Through-hole Desoldering | Stations: CDD, DIU, DDU, DMU Tool: DS360 Modules: MSE, MS |
| C360002 | Micro Desoldering Tip Ø 0.8 mm Ø 0.032 in |  | Through-hole Desoldering | Stations: CDD, DIU, DDU, DMU Tool: DS360 Modules: MSE, MS |
| C360003 | Micro Desoldering Tip Ø 1 mm Ø 0.039 in |  | Through-hole Desoldering | Stations: CDD, DIU, DDU, DMU Tool: DS360 Modules: MSE, MS |
| C360004 | Micro Desoldering Tip Ø 1.2 mm Ø 0.047 in |  | Through-hole Desoldering | Stations: CDD, DIU, DDU, DMU Tool: DS360 Modules: MSE, MS |
| C360007 | Micro Desoldering Tip Ø 1.4 mm Ø 0.055 in |  | Through-hole Desoldering | Stations: CDD, DIU, DDU, DMU Tool: DS360 Modules: MSE, MS |
| C360006 | Micro Desoldering Tip Ø 1.5 mm Ø 0.059 in |  | Through-hole Desoldering | Stations: CDD, DIU, DDU, DMU Tool: DS360 Modules: MSE, MS |
| C360011 | Micro Desoldering Tip Ø 0.6 mm Pad Ø 0.024 in |  | Pad desoldering | Stations: CDD, DIU, DDU, DMU Tool: DS360 Modules: MSE, MS |

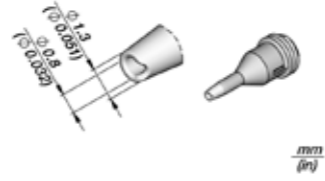
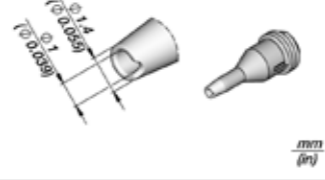
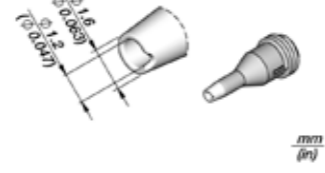
C360 Tip Range for DS360 Micro Desoldering Iron

| Ref. | Description | Image and dimensions | Suggested components | Compatible with |
|----------------|---|---|----------------------|--|
| C360012 | Micro Desoldering Tip Ø 0.8 mm Pad Ø 0.032 in |  | Pad desoldering | Stations: CDD, DIU, DDU, DMU Tool: DS360 Modules: MSE, MS |
| C360013 | Micro Desoldering Tip Ø 1 mm Pad Ø 0.039 in |  | Pad desoldering | Stations: CDD, DIU, DDU, DMU Tool: DS360 Modules: MSE, MS |
| C360014 | Micro Desoldering Tip Ø 1.2 mm Pad Ø 0.047 in |  | Pad desoldering | Stations: CDD, DIU, DDU, DMU Tool: DS360 Modules: MSE, MS |

C560 Tip Range
for DR560 Desoldering Iron

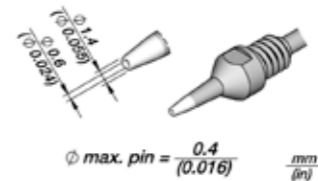
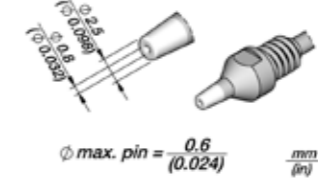
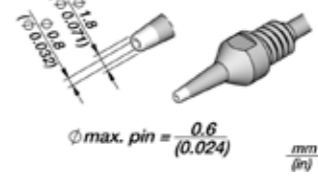
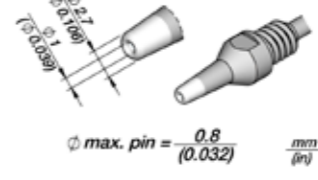
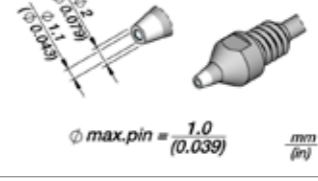
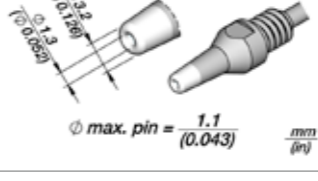

| Ref. | Description | Image and dimensions | Suggested components | Compatible with |
|----------------|---|---|--------------------------|---|
| C560001 | Desoldering Tip Ø 0.6 mm HT Ø 0.024 in |  | Through-hole Desoldering | Stations: DIU, DDU, DMU Tool: DR560 Modules: MSE, MS |
| C560014 | Desoldering Tip Ø 0.8 mm Ø 0.032 in |  | Through-hole Desoldering | Stations: DIU, DDU, DMU Tool: DR560 Modules: MSE, MS |
| C560002 | Desoldering Tip Ø 0.8 mm HT Ø 0.032 in |  | Through-hole Desoldering | Stations: DIU, DDU, DMU Tool: DR560 Modules: MSE, MS |
| C560003 | Desoldering Tip Ø 1 mm Ø 0.039 in |  | Through-hole Desoldering | Stations: DIU, DDU, DMU Tool: DR560 Modules: MSE, MS |
| C560017 | Desoldering Tip Ø 1.1 mm Ø 0.043 in |  | Through-hole Desoldering | Stations: DIU, DDU, DMU Tool: DR560 Modules: MSE, MS |
| C560004 | Desoldering Tip Ø 1.3 x Ø 3.2 mm Ø 0.052 x Ø 0.126 in |  | Through-hole Desoldering | Stations: DIU, DDU, DMU Tool: DR560 Modules: MSE, MS |
| C560009 | Desoldering Tip Ø 1.3 x Ø 5 mm Ø 0.052 x Ø 0.197 in |  | Through-hole Desoldering | Stations: DIU, DDU, DMU Tool: DR560 Modules: MSE, MS |

C560 Tip Range for DR560 Desoldering Iron

| | Ref. | Description | Image and dimensions | Suggested components | Compatible with |
|----------------|----------------|--|--|-----------------------------------|---|
| | C560005 | Desoldering Tip Ø 1.5 mm Ø 0.059 in | $\varnothing \text{ max. pin} = \frac{1.3}{(0.051)} \frac{\text{mm}}{\text{in}}$ | Through-hole Desoldering | Stations: DIU, DDU, DMU Tool: DR560 Modules: MSE, MS |
| | C560006 | Desoldering Tip Ø 1.9 mm Ø 0.075 in | $\varnothing \text{ max. pin} = \frac{1.7}{(0.067)} \frac{\text{mm}}{\text{in}}$ | Through-hole Desoldering | Stations: DIU, DDU, DMU Tool: DR560 Modules: MSE, MS |
| | C560018 | Desoldering Tip Ø 2.2 mm Ø 0.087 in | $\varnothing \text{ max. pin} = \frac{2}{(0.079)} \frac{\text{mm}}{\text{in}}$ | Through-hole Desoldering | Stations: DIU, DDU, DMU Tool: DR560 Modules: MSE, MS |
| | C560007 | Desoldering Tip Ø 2.4 mm Ø 0.095 in | $\varnothing \text{ max. pin} = \frac{2.2}{(0.087)} \frac{\text{mm}}{\text{in}}$ | Through-hole Desoldering | Stations: DIU, DDU, DMU Tool: DR560 Modules: MSE, MS |
| | C560015 | Desoldering Tip Ø 3 mm Ø 0.118 in | $\varnothing \text{ max. pin} = \frac{2.8}{(0.110)} \frac{\text{mm}}{\text{in}}$ | Through-hole Desoldering | Stations: DIU, DDU, DMU Tool: DR560 Modules: MSE, MS |
| | | C560011 | Desoldering Tip Ø 0.6 mm HT Pad Ø 0.024 in | $\frac{\text{mm}}{\text{in}}$ | Pad desoldering |
| C560012 | | Desoldering Tip Ø 0.8 mm HT Pad Ø 0.032 in | $\frac{\text{mm}}{\text{in}}$ | Pad desoldering | Stations: DIU, DDU, DMU Tool: DR560 Modules: MSE, MS |
| C560013 | | Desoldering Tip Ø 1 mm Pad Ø 0.039 in | $\frac{\text{mm}}{\text{in}}$ | Pad desoldering | Stations: DIU, DDU, DMU Tool: DR560 Modules: MSE, MS |



W140 Blade Cartridge Range
for **WS140** High-Temperature Precision
Wire Stripper Tweezers

| | Ref. | Description | Image and dimensions | Suggested components | Compatible with |
|--|----------------|--|--|------------------------------|-----------------------------------|
| | W14014G | Single-Hole Cartridges Solid Wire 14 AWG | STRANDED 16 (7 x 24) AWG SOLID 14 AWG $\frac{\text{mm}}{\text{in}}$ | Wire insulation stripping | Station: WSS Tool: WS140 |
| | W14016G | Single-Hole Cartridges Solid Wire 16 AWG | STRANDED 18 (19 x 30) AWG SOLID 16 AWG $\frac{\text{mm}}{\text{in}}$ | Wire insulation stripping | Station: WSS Tool: WS140 |
| | W14018G | Single-Hole Cartridges Solid Wire 18 AWG | STRANDED 20 (19 x 32) AWG SOLID 18 AWG $\frac{\text{mm}}{\text{in}}$ | Wire insulation stripping | Station: WSS Tool: WS140 |
| | W14020G | Single-Hole Cartridges Solid Wire 20 AWG | STRANDED 22 (19 x 34) AWG SOLID 20 AWG $\frac{\text{mm}}{\text{in}}$ | Wire insulation stripping | Station: WSS Tool: WS140 |
| | W14022G | Single-Hole Cartridges Solid Wire 22 AWG | STRANDED 24 (19 x 36) AWG SOLID 22 AWG $\frac{\text{mm}}{\text{in}}$ | Wire insulation stripping | Station: WSS Tool: WS140 |
| | W14024G | Single-Hole Cartridges Solid Wire 24 AWG | STRANDED 26 (19 x 38) AWG SOLID 24 AWG $\frac{\text{mm}}{\text{in}}$ | Wire insulation stripping | Station: WSS Tool: WS140 |
| | W14026G | Single-Hole Cartridges Solid Wire 26 AWG | STRANDED 28 (19 x 40) AWG SOLID 26 AWG $\frac{\text{mm}}{\text{in}}$ | Wire insulation stripping | Station: WSS Tool: WS140 |
| | W14028G | Single-Hole Cartridges Solid Wire 28 AWG | STRANDED 30 (19 x 42) AWG SOLID 28 AWG $\frac{\text{mm}}{\text{in}}$ | Wire insulation stripping | Station: WSS Tool: WS140 |

W140 Blade Cartridge Range for WS140 High-Temperature Precision Wire Stripper Tweezers

| Ref. | Description | Image and dimensions | Suggested components | Compatible with |
|----------------|--|----------------------|---------------------------|-----------------------------------|
| W14030G | Single-Hole Cartridges Solid Wire 30 AWG | | Wire insulation stripping | Station: WSS Tool: WS140 |
| W14032G | Single-Hole Cartridges Solid Wire 32 AWG | | Wire insulation stripping | Station: WSS Tool: WS140 |
| W14034G | Single-Hole Cartridges Solid Wire 34 AWG | | Wire insulation stripping | Station: WSS Tool: WS140 |
| W14036G | Single-Hole Cartridges Solid Wire 36 AWG | | Wire insulation stripping | Station: WSS Tool: WS140 |
| W14037G | Single-Hole Cartridges Solid Wire 37 AWG | | Wire insulation stripping | Station: WSS Tool: WS140 |
| W14038G | Single-Hole Cartridges Solid Wire 38 AWG | | Wire insulation stripping | Station: WSS Tool: WS140 |
| W14040G | Single-Hole Cartridges Solid Wire 40 AWG | | Wire insulation stripping | Station: WSS Tool: WS140 |
| W14003F | Flat Cartridges 3 mm | | Wire insulation stripping | Station: WSS Tool: WS140 |
| W14005F | Flat Cartridges 5 mm | | Wire insulation stripping | Station: WSS Tool: WS140 |

W440 Blade Cartridge Range for WS440 High-Temperature Wire Stripper Tweezers



| Ref. | Description | Image and dimensions | Suggested components | Compatible with |
|----------------|--|----------------------|---------------------------|-----------------------------------|
| W440021 | Multi-Hole Cartridges Solid Wire 34 - 22 AWG | | Wire insulation stripping | Station: WSB Tool: WS440 |
| W440023 | Multi-Hole Cartridges Solid Wire 26 - 16 AWG | | Wire insulation stripping | Station: WSB Tool: WS440 |
| W440025 | Flat Cartridges 12.5 mm | | Wire insulation stripping | Station: WSB Tool: WS440 |

JBC

The Soldering Co.

 **T&Ch**
Technology Chemical, S.L.