

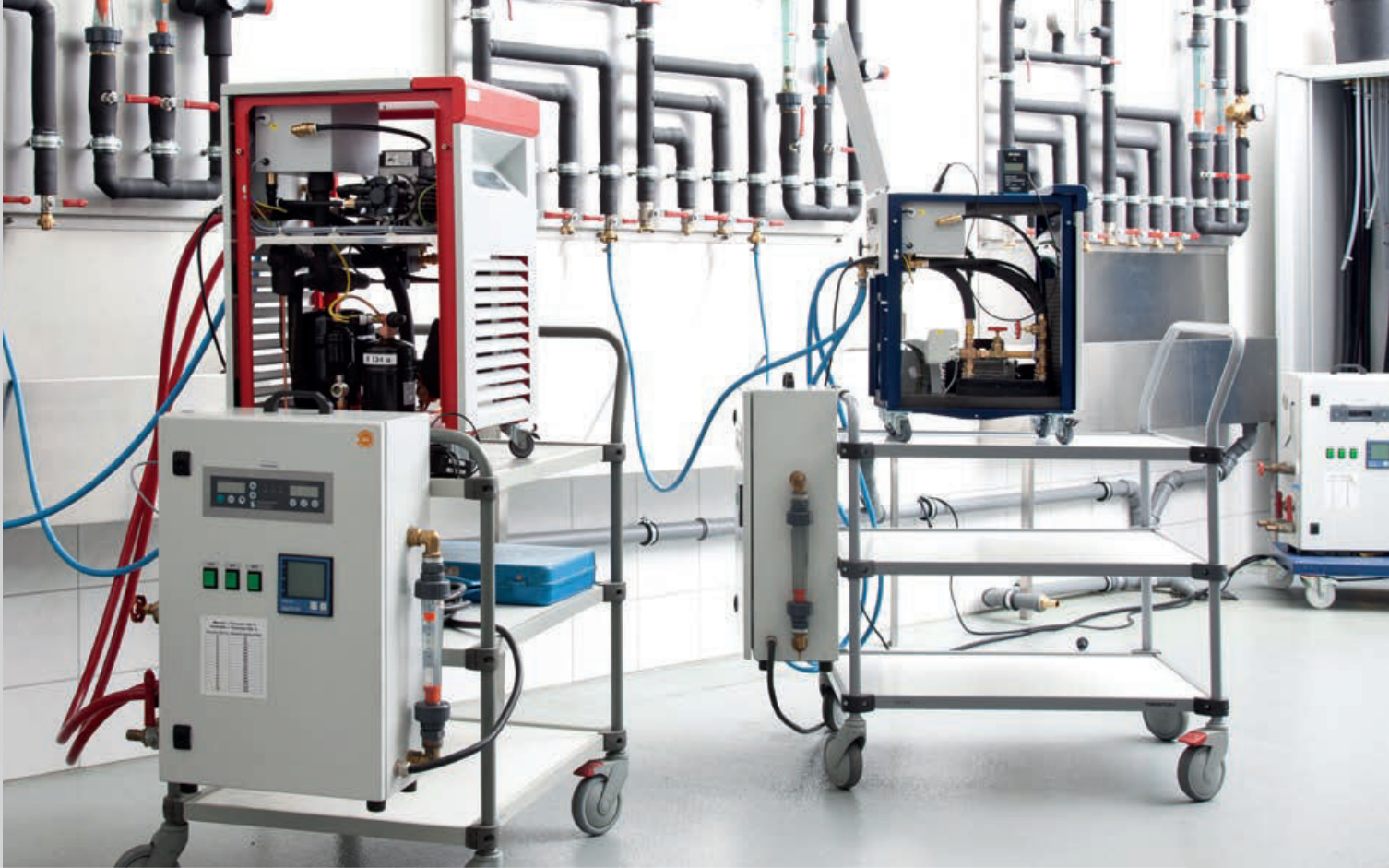

# Trolleys





## Freedom of mobility with trolleys

### Increased productivity with mobility

Work is not always confined to a single workstation and tools must be moved around accordingly. Lightweight trolleys are ideal for this situation, significantly increasing productivity up to 30%.

The trolleys provide extra work or storage space and can be used, for example, to transport various items, to store measuring units and keep a buffer stock on a production line.

Each task is different and requires dedicated tools. Due to their modularity and versatile accessory components, trolleys are easy to design and adapt to suit a multitude of users and applications.





Universal trolley WTR

Most often combined with WB workstations to provide extra storage space. A good adjustable PC station, measuring station or mobile storage, best suitable for moving equipment around the workstation.



Multi trolley

With three widths and two heights available this trolley is suitable for a wide range of needs. The sturdy shelves can be adjusted and tilted, making it easy to arrange different types of equipment, even heavy loads.



Basic trolley

This trolley can be equipped with shelves, tops and other accessories to fit any application, such as transportation or tool storage.



Adjustable trolley TRTA

For general use wherever a good transportation and storage solution is needed. Two or four shelves available; height of the shelves can be adjusted. Mesh panels can be installed at the ends or on the sides. Also a SMD reel holder version available.



Mobile workstation MLC

An ergonomic and versatile tool with key qualities such as light weight, small size and excellent mobility. Used wherever a laptop is needed on the go.



Storage trolley

Simple solution for mobile storage. The shelves are fitted with rubber mats and the middle shelf is adjustable.



Ergo trolley

Most often combined with Concept workstations to provide extra work and storage space. Can be equipped with a lower shelf, available separately.



SAP trolley

Most often combined with TP workstations to provide extra workspace. Can be equipped with a lower shelf, available separately.



CTR trolley

Most often combined with WB workstations to provide extra workspace. Lower shelf is integrated.

# Universal trolley WTR

A good quality, versatile trolley, PC-station, measuring station or mobile storage trolley. Modern industrial design.

The standard trolley has 3 shelves (TS 605), size 650 x 530 mm. Height adjustment of shelves is by allen-key. The vertical profiles are of aluminium. Frames are of epoxy powder coated steel: light grey RAL 7035. The worktops are of 25 mm laminated particle board. Four swivel castors (Ø 125 mm) two of which have brakes, overall height of castor 141 mm.



## Universal trolley WTR

Name	Size W x D x H mm	Max load kg	Code	Code ESD
1. Universal trolley	660 x 650 x 1415	150	WTR140	WTR140 ESD
2. Extra shelf	530 x 650	50	TS605	TS605 ESD
3. Adjustable shelf*	530 x 650	50	TAS605	TAS605 ESD
4. Bin profile	Length 525		BP50	BP50 ESD
5. Power channel WJK 40**	Length 470 mm		WJK40	WJK40
6. Keyboard tray NT	525 x 399 x 133 (outer) 500 x 250 x 110 (inner)		-	NT 500 ESD

\*Continuous adjustment for depth, height and angle.

\*\* May be fitted with a choice of components, ordered separately. All meet with CE requirements. 3 m cable is included.

### \*\*COMPONENTS FOR POWER CHANNEL WJK 40

E1 Double socket (max. 5 pcs/1 cable)	E6 Data connector/shielded for Cat.6 cable
E2 Switch	E7 Data connector/without screen for Cat.5 cable
E3 Automatic fuse 10 A	E8 Pneumatic, quick coupling 3/8"
E4 Automatic fuse/earth leakage switch 10 A/30 mA	
E5 Emergency-stop-switch	





# Multi trolley

Multi trolleys provide an ergonomic mobile workstation. Multi trolleys are available in three different widths: M500, M750 and M900. This means that all our module-sized accessories can be used with the trolleys.

The sturdy shelves can be height-adjusted and tilted. They are also equipped with borders and rubber mats, which keep the load in place.

Multi trolleys support heavy loads, but they are easy to move as well, making it simple to transport heavy equipment, such as measuring units. They are equipped with four swivel castors (Ø 100 mm), two of which have brakes.

## Multi trolleys

Name	Module	Outer dims W x D x H mm	Code	Code ESD
Multi trolley 1	M500	530 x 715 x 1130	C 721 41 001P	C 721 49 001P
Multi trolley 1	M750	780 x 715 x 1130	C 721 41 002P	C 721 49 002P
Multi trolley 1	M900	935 x 715 x 1130	C 721 41 003P	C 721 49 003P
Multi trolley 2	M500	530 x 715 x 1630	C 722 41 001P	C 722 49 001P
Multi trolley 2	M750	780 x 715 x 1630	C 722 41 002P	C 722 49 002P
Multi trolley 2	M900	935 x 715 x 1630	C 722 41 003P	C 722 49 003P

Multi trolley 1 includes: one bottom shelf and one adjustable shelf, depth: 505 mm.

Multi trolley 2 includes: one bottom shelf and three adjustable shelves, depth 650 mm.



Multi trolley 2



Multi trolley 1

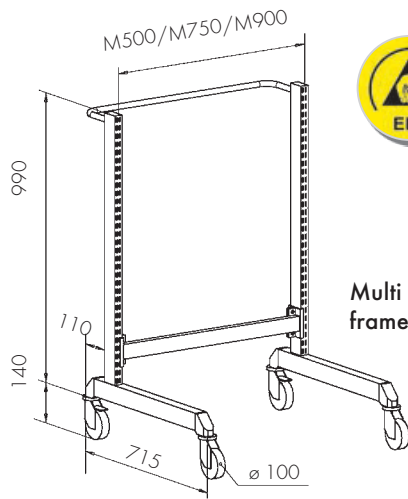

Multi trolley 1 frame

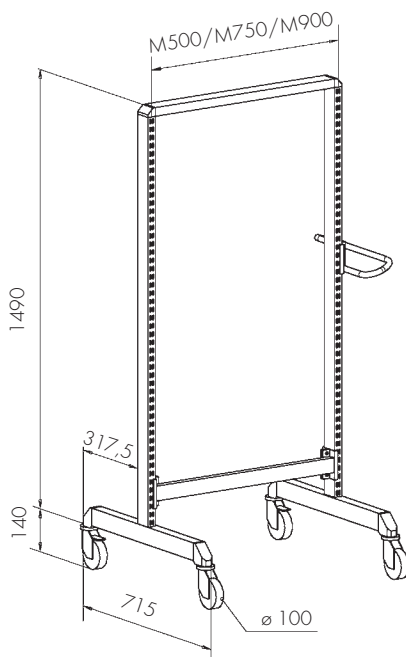

Multi trolley 2 frame

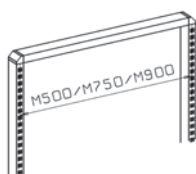
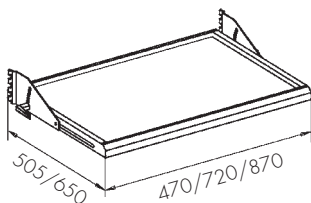

## Multi trolley frame

Name	Module	Size W x D x H mm	Max load kg	Code	Code ESD
Multi trolley 1 frame	M500	530 x 715 x 1130	300	860 812-41	860 812-49
Multi trolley 2 frame	M500	530 x 715 x 1630	300	860 818-41	860 818-49
Multi trolley 1 frame	M750	780 x 715 x 1130	300	860 154-41	860 154-49
Multi trolley 2 frame	M750	780 x 715 x 1630	300	860 156-41	860 156-49
Multi trolley 1 frame	M900	935 x 715 x 1130	300	860 155-41	860 155-49
Multi trolley 2 frame	M900	935 x 715 x 1630	300	860 157-41	860 157-49

## Multi trolley frame dimensions

Multi trolley	Total height, mm	Depth, mm	Module width	Total width, mm
Frame 1	1130	715	M500/M750/M900	530/780/935
Frame 2	1630	715	M500/M750/M900	530/780/935

## Bottom shelf

Name	Module	Size W x D mm	Max load kg	Code	Code ESD
Bottom shelf*	M500	470 x 505	100	860 846-41	860 846-49
Bottom shelf	M500	470 x 650	100	860 847-41	860 847-49
Bottom shelf*	M750	720 x 505	100	860 057-41	860 057-49
Bottom shelf	M750	720 x 650	100	860 067-41	860 067-49
Bottom shelf*	M900	870 x 505	100	860 059-41	860 059-49
Bottom shelf	M900	870 x 650	100	860 069-41	860 069-49

\*Compatible only with Multi trolley 1.

Adjustable shelves are equipped with an ESD mat (49) or rubber mat (41).

## Adjustable shelf for trolleys

Name	Module	Size W x D mm	Max load kg	Code ESD
Adjustable shelf	M500	470 x 505	100	921 49 001
Adjustable shelf	M500	470 x 650	100	921 49 002
Adjustable shelf	M750	720 x 505	100	921 49 005
Adjustable shelf	M750	720 x 650	100	921 49 006
Adjustable shelf	M900	870 x 505	100	921 49 009
Adjustable shelf	M900	870 x 650	100	921 49 010

Adjustable shelves are equipped with an ESD mat (49) or rubber mat (41).

## Adjustable shelf, stepless depth adjustment

Name	Module	Size W x D mm	Max load kg	Code ESD
Adjustable shelf, stepless depth adjustment	M500	470 x 505	50	921 49 003
Adjustable shelf, stepless depth adjustment	M500	470 x 650	50	921 49 004
Adjustable shelf, stepless depth adjustment	M750	720 x 505	50	921 49 007
Adjustable shelf, stepless depth adjustment	M750	720 x 650	50	921 49 008
Adjustable shelf, stepless depth adjustment	M900	870 x 505	50	921 49 011
Adjustable shelf, stepless depth adjustment	M900	870 x 650	50	921 49 012

Adjustable shelves are equipped with an ESD mat (49) or rubber mat (41).



### Modular size

The modular (M) size refers to the distance between two upright tubes from the middle of the tube. The modular size is used to find the appropriate accessories.

# Basic trolley



Equip your trolleys with shelves, tops and other accessories to fit any application, such as transportation or tool storage. All trolleys are equipped with four swivel castors (Ø 125 mm), two of which have brakes. The basic trolley can be combined with all the M750 accessories.

## Basic trolleys

Name	Size W x D x H mm	Max load kg	Code
Basic trolley 1	800 x 715 x 1650	350	C 740 49 101
Basic trolley 3	800 x 715 x 1625	350	C 740 49 003
Basic trolley 5	800 x 715 x 1625	350	C 740 49 105
Basic trolley frame*	800 x 715 x 1625	350	859 859-49

\*Basic trolley frame includes bottom shelf and ESD mat.



Basic trolley 1



Basic trolley 3

## Basic trolley accessories

Name	Size W x D x H mm	Max load kg	Code
Bottom shelf with ESD mat	720 x 560 x 32	150	852 719-49
Shelf with ESD mat*	720 x 560 x 32	150	852 720-49
Steel shelf*	720 x 560 x 32	150	852 685-49
Steel shelf	720 x 560 x 32	150	852 665-49
Extendable shelf*	720 x 580 x 33	50	852 687-49
Paper roll holder	Roll dimensions max: width 240 mm, Ø 230 mm)		860 310-49
Perforated back panel	718 x 389		861 511-49
Perforated back panel	718 x 612		861 512-49
Perforated back panel, insulated	718 x 612		861 701-49
Perforated back panel	718 x 1003		861 514-49

Trolleys can be combined with all the M750 accessories. For R-hooks, see p. 116.

\*including brackets



Basic trolley 5

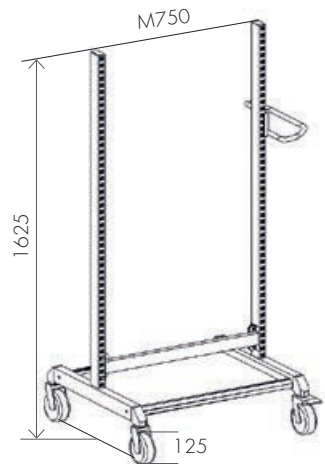

Basic trolley frame



Check the entire Basic trolley selection from our Distinctive Workshops catalogue.



[treston.com/company/catalogues-and-brochures](http://treston.com/company/catalogues-and-brochures)



WATCH THIS ANIMATION showcasing the versatile usage options of our technical furniture: Basic trolley | <https://vimeo.com/212715615>



# Adjustable trolley TRTA

For general use in workshops, offices, production areas and hospitals. Shelves are powder coated steel, RAL 7035 ESD, height 28 mm. All shelves are individually adjustable. The structure is light but sturdy. The end-frames of the trolley are made of round, powder coated steel tube (25 mm). Four swivel castors (Ø 125 mm), two of which have brakes.



## Adjustable trolley TRTA

Name	Size W x D x H mm	Shelf size W x D mm	Max load kg	Code	Code ESD
2-shelf trolley*	890 x 530 x 1020	800 x 430	150	TRTA4082	TRTA4082 ESD
2-shelf trolley*	1090 x 530 x 1020	1000 x 430	150	TRTA4102	TRTA4102 ESD
2-shelf trolley*	890 x 630 x 1020	800 x 530	150	TRTA5082	TRTA5082 ESD
2-shelf trolley*	1090 x 630 x 1020	1000 x 530	150	TRTA5102	TRTA5102 ESD
4-shelf trolley**	1090 x 530 x 1515	1000 x 430	300	TRTA4104	TRTA4104 ESD
4-shelf trolley**	1090 x 630 x 1515	1000 x 530	300	TRTA5104	TRTA5104 ESD

\* Shelf adjustments between 200-770 mm

\*\* Shelf adjustments between 200-1340 mm

## Extra shelves TRHA

Name	Shelf size W x D mm	Max load kg	Code	Code ESD
Extra shelf	800 x 430	50	TRHA408	TRHA408 ESD
Extra shelf	1000 x 430	50	TRHA410	TRHA410 ESD
Extra shelf	800 x 530	50	TRHA508	TRHA508 ESD
Extra shelf	1000 x 530	50	TRHA510	TRHA510 ESD

## End mesh panels NET2

Name	Size W x D mm	Set	Code ESD
End mesh panel	604 x 364	Incl. 2 panels	NET2

The mesh panels can be installed at the ends of the trolley or on the sides. An angle bracket is set on the edge of the upper and lower shelf and the mesh is screwed into place. The 4-shelf trolley can hold 2 mesh panels on top of each other.

## Document holder DSA4

Name	Size	Code ESD
Document holder	A4	DSA4 ESD

Semiconductive epoxy powder coated steel. Includes two magnets.

## Low M-divider hoops LDH

Name	Size	Code
Divider hoops	460 x 315	LDH

Steplessly adjustable. 4 pcs per set. M-shape (the lowest point 105 mm from shelf). Suitable only 430 mm deep shelves.



Document holder



Low M-divider hoops LDH

# Reel holder trolley RRT

The adjustable reel holder trolley is compatible with SMD reels, and suitable for transport and stocking of them. All parts are powder coated steel, RAL 7035 ESD. The trolley has four perforated steel shelves, 1090 x 460 x 28 mm. All shelves are individually adjustable between 200-1605 mm.

The zinc plated reel racks that fit into the shelves are to be ordered separately. The structure is light but sturdy. The end-frames of the trolley are made of round, powder coated steel tube (25 mm). Four turning castors with brakes (Ø 125 mm). The load capacity of one shelf is 50 kg, and the load capacity of the trolley is 200 kg.

## Reel holder trolley RRT

Name	Size W x D x H mm	Max load kg	Code ESD
1. Reel holder trolley	1100 x 530 x 1780	200	RRT ESD
2. Reel rack	960 x 426 x 254	50	RR ESD-Z
3. Document holder	A4		DSA4 ESD

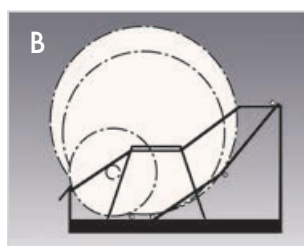
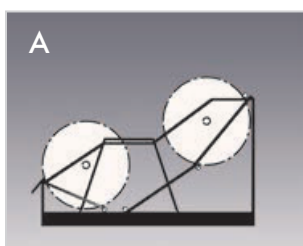
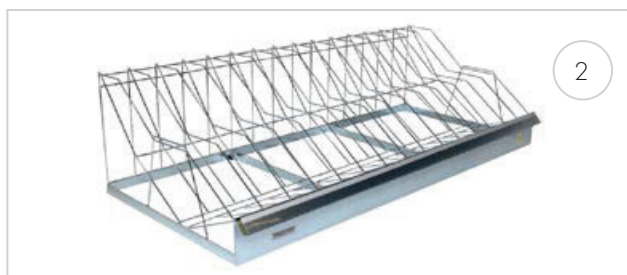

In picture A: Side view of spools and reel racks. The capacity of one rack is 30 fixed compartments for 7" spools of 60 mm width.

In picture B: Side view of spools and reel racks. The capacity of one rack is 15 fixed compartments for 13" and 15" spools of 60 mm width.

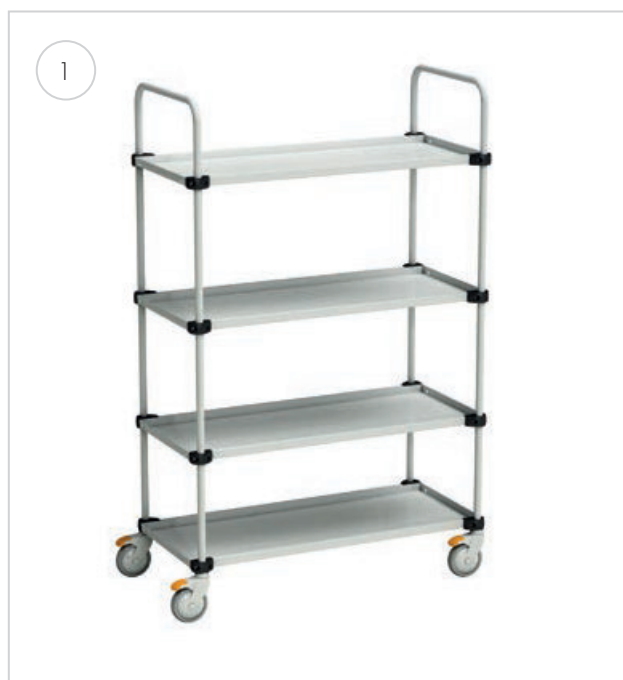

# Mobile workstation MLC



The mobile workstations equipped with a laptop enclosure are lockable.

The MLC 405 is a light weight mobile workstation designed to be ergonomic and provide excellent mobility. Accessories can be mounted on the Euro-rail surrounding the work surface. A laptop computer can be placed either on the work surface or under it. The rear recess allows you to conceal the laptop keyboard but leave the screen open and visible. An independent keyboard can be stored either on the work surface or on a keyboard tray (pictured, sold separately). Perforations around the sides and rear of the concealed compartment allow for cables to be connected to the laptop.

- The hinged work surface is made from low-pressure laminate.
- The frame consists of two interlocking aluminium profiles.
- A laptop can be housed on the worktop or stored underneath it to reveal only the screen.
- Cable connections are easily attached through holes around the storage compartment.
- Steel legs with four Ø125 mm castors, two of which are braked.

## Mobile workstation MLC

Name	Size W x D x H mm	Top size mm	Max load kg	Code	Code ESD
Mobile workstation	590 x 540 x 800-1200*	520 x 370 x 25	12	MLC405 PG	MLC405 PG ESD

\*Height is adjusted by gas spring between 800-1200 mm.

## Mobile workstation accessories

Name		Code
1. Keyboard and mouse tray	210 x 620 mm. Equipped with a wrist support.	KH620N
2. Binder mount	Fits a single 75 mm wide binder.	FH1
3. Binder mount	Fits three 75 mm wide binders.	FH3
4. Accessories basket	Blue bin, int. dim. 230 x 155 x 140 mm	AB1930
5. LCD bracket	Load capacity 15 kg, mounting holes 75 x 75 / 100 x 100 apart	MH
6. LCD support arm	For the attachment of MH and MY supports. Max 22" screen.	MS
7. Tablet bracket	For 7-10" tablets. Requires either an MH, MA or MA2 swivel arm.	MY

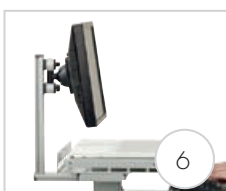

# Trolleys for additional workspace

**Storage trolley** is an easy solution for mobile storage, the storage trolley has an adjustable middle shelf, and the shelves are fitted with standard rubber mats.

**Ergo trolley** provides extra workspace for the Concept workbench. Lower shelf is available separately. Height adjustment with allen key between 650-900 mm.

**SAP trolley** provides extra workspace for the TP workbench. Lower shelf is available separately. Height adjustment with allen key between 650-900 mm.

**CTR trolley** provides extra workspace for the WB workbench. Lower shelf is integrated. Height adjustment with allen key between 690-990 mm.



## Trolleys for additional workspace

Name	Size W x D x H mm	Max load kg	Code	Code ESD
1. Storage trolley	650 x 450 x 775	3 x 30	852 773-41	852 773-49
2. Ergo trolley	750 x 500 x 650-900	150	-	860 422-49P
Lower shelf for Ergo trolley	595 x 480	-	-	860 425-49
3. SAP trolley	700 x 500	150	SAP507	SAP507 ESD
SAP trolley	1000 x 700	150	SAP710	SAP710 ESD
SAP trolley	1500 x 700	150	SAP715	SAP715 ESD
Lower shelf for SAP trolley	700 x 500	40	AT507	AT507 ESD
Lower shelf for SAP trolley	1000 x 700	40	AT710	AT710 ESD
Handle for SAP trolley	depth 500		PUSH50	PUSH50
Handle for SAP trolley	depth 700		PUSH70	PUSH70
4. CTR trolley	700 x 500	75 / shelf	CTR705	CTR705 ESD

All the light-duty trolleys are equipped with four swivel castors (ø 100 mm), two of which have brakes. ESD versions are also available.



Storage trolley



Ergo trolley



SAP trolley



CTR trolley



Check our carton trolley selection on page 134.



# Drawer units





## Versatile drawer units

Since work is not always performed in the same place, we provide a comprehensive range of different drawer units for a variety of purposes. You can fix any drawer unit from the same series under a worktop or on a plinth, or equip them with castors to take along to your next workstation.

### Efficient storage and control

Our drawer units are great for storing tools and supplies. It is surprising how much time is spent finding tools and other items if they are not stored systematically. The versatile interior combinations of our drawer units guarantee that your supplies are always at hand and in good order.

### A comprehensive range of drawer units

We promise that you will find a drawer unit that meets your requirements in our comprehensive range. You can choose from several different heights and drawer and interior combinations. We have selected some combinations for this brochure. For more options, please contact: [sales@treston.com](mailto:sales@treston.com).

### Drawer units for light loads

These drawer units are designed for storing lightweight items, for example in a testing laboratory or in an office environment.





### Light steel cabinet LMC

These steel cabinets are an ideal way of providing individual secure storage for your staff. Drawers are mounted on telescopic ball race slides. Four cabinet sizes, including one drawer/cupboard combination.

### Drawer units 30 and 35

These drawer units are fastened under a workbench to provide storage space. Choose from single drawer, two drawers or drawer cabinet. If additional drawers are needed, they can be easily attached to each other. The drawers can be locked to protect the contents.



### Drawer unit 45

Choose from two frame heights: 56 or 66 cm, with a plinth for a stand alone solution or with castors for a trolley version. The drawer unit 45 can also be attached under the worktop. All the drawer units have central locking.



# Three-level locking system

The majority of our drawer units and cabinets can be equipped with a three-level locking system. This allows both serialisations of individual and identical locks. Contact your Treston representative for additional information. The locking services are always specified for the order.

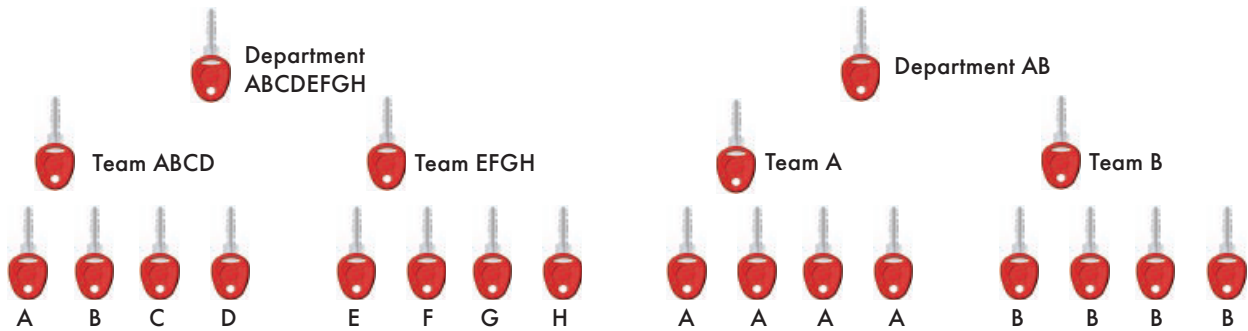

## Serialisation of individual locks

Each drawer or cabinet has an individual lock in a production unit, but a master key opens all the locks of the unit. The master keys can also be serialised and the third-level key opens all the drawers and cabinets of all the production units.

## Serialisation of identical locks

Each team member needs only one key to access all the drawers and cabinets in a production unit. A master key opens all the drawers and cabinets of all the production units and can also be serialised.

# Light steel cabinet LMC

These steel cabinets are an ideal way of providing individual secure storage for your staff. Drawers are mounted on telescopic ball race slides. Four cabinet sizes, including one drawer/cupboard combination. The cabinet

frames are epoxy powder coated steel; drawer fronts are composite board with aluminium handles. Colour light grey, RAL 7035. Mount on benches with brackets (included).

Suitable for WB/TP workbenches and SAP/WTR trolleys



### Light steel cabinet, load capacity 15 kg/drawer, 70 % opening

Code	LMC01	LMC02	LMC04	LMC04D
Code ESD	LMC01 ESD	LMC02 ESD	LMC04 ESD	LMC04D ESD
Outer dims W x D x H mm	370 x 460 x 135	370 x 460 x 245	370 x 460 x 455	370 x 460 x 455
Includes drawers (outer height mm)	1 x 100	2 x 100	4 x 100	1 x 100 + cupboard, height 300 mm, open to right

Internal drawer dimensions: 278 x 438 x 75 mm

### Cover LMCK2

Description	Code
Needed for mounting cabinets to WB benches and WTR trolley.	LMCK2

# Drawer units 30 and 35

These drawer units are fastened under a workbench to provide storage space. Choose from single drawer, two drawers or drawer cabinet. If additional drawers are

needed, they can be easily attached to each other. The drawers can be locked to protect the contents.

Drawer cabinet 35/47 is suitable for storing upright folders.



Drawer units 30 and 35, load capacity 10 kg/drawer, 80 % opening

	30/15	30/22	35/47
<b>Code</b>	859 330-49	859 340-49	860 972-49
Outer dims W x D x H mm	300 x 454 x 150	300 x 454 x 220	350 x 470 x 470
Includes drawers (outer height mm)	1 x 150	2 x 110	1 x 110 + cupboard, height
<b>Internal drawer dimensions:</b>	<b>255 x 400 x 120 mm</b>	<b>255 x 400 x 75 mm</b>	<b>300 x 400 x 70 mm</b>

Fastening sets for drawer unit 30 and 35 should be selected according to the type of the workbench

Depth	600 mm	700 mm	750 mm	800 mm	900 mm
Concept, allen key adjustable	860 931-49	-	860 930-49	-	860 239-49
Concept, hand crank adjustable	-	-	860 930-49	-	-
Concept, motor adjustable	854 463-49	-	854 463-49	-	854 463-49
TowerLine, LMT	-	-	854 463-49	-	-
TP / TPH	-	855 054-49	-	-	855 054-49
WB	-	-	-	855 054-49	-

Not adapted to Concept handcrank bench (depth 600 mm).

Drawer unit 30/22 is now available with a secure and up-to-date electronic code lock.

This electronic locking system replaces keys with a numerical code. The code is easy to change when needed, for example, for a different user and thus this drawer unit is an excellent choice when high convenience and confidentiality are needed.

The locking system is operated with 2 x AAA batteries and is thus independent from an external power supply. Due to an automatic low power (sleep) mode, the batteries last long, and even when the battery power is low, the lock can still be opened 300 more times.

Drawer unit 30/22 with electronic code lock, order code 720010-49.



# Drawer unit 45

Centrally locked high quality steel drawer units for storage of tools and small components. Mounted under workbenches with brackets. Also available with castors as a trolley version. Drawer units are epoxy powder coated in grey, RAL 7035. Central locking. Full width drawer handle in anodised aluminium. Smooth and quiet telescopic ball-race runners and clear opening of 375 mm. Load capacity 30 kg/drawer. Drawer size 380 x 500 mm.

All of our drawer units are also available as 100% extendable versions with a load-bearing capacity of 60 kg/drawer. Our drawer units are suitable for use in EPAs. Our mobile trolleys are available in both ESD and non-ESD versions.



Choose the drawer unit according to your needs; with castors, plinth or no plinth.

Load capacity 150 kg, 4 swivel castors (ø 100 mm), 2 with brakes. The trolley version comes with a rubber mat that stops items from sliding on the surface.

Combination name

**45/56-1**

Width Height Version



The maximum load capacity of 100% extendable drawers is 60 kg!

## Drawer unit 45/56, 75% opening, load capacity 30 kg/drawer

	L-45/56-1	L-45/56-2	L-45/56-3	L-45/56-4	L-45/56-7	L-45/56-11
Standard	606 49 001	606 49 002	606 49 003	606 49 004	606 49 007	606 49 0011
With plinth	606 49 011	606 49 012	606 49 013	606 49 014	606 49 017	606 49 0021
With castors	606 49 021	606 49 022	606 49 023	606 49 024	606 49 027	-
Height (mm) of the drawer	5 x 100	2 x 100 2 x 150	3 x 100 1 x 200	1 x 100 2 x 200	2 x 150 1 x 200	1 x 200 1 x 300

Internal drawer dimensions: 380 x 500 x 90/140/190/290 mm.

## Drawer unit 45/66, 75% opening, load capacity 30 kg/drawer

	L-45/66-1	L-45/66-2	L-45/66-3	L-45/66-4	L-45/66-5	L-45/66-6	L-45/66-7
Standard	607 49 001	607 49 002	607 49 003	607 49 004	607 49 005	607 49 006	607 49 007
With plinth	607 49 011	607 49 012	607 49 013	607 49 014	607 49 015	607 49 016	607 49 017
With castors	607 49 021	607 49 022	607 49 023	607 49 024	607 49 025	607 49 026	607 49 027
Height (mm) of the drawer	6 x 100	3 x 100 2 x 150	1 x 100 2 x 150 1 x 200	4 x 150	4 x 100 1 x 200	2 x 100 2 x 200	3 x 200

Internal drawer dimensions: 380 x 500 x 90/140/190 mm.